

Columbus**JACK**/Regent



**Model 50J25178-10E1**  
**10 Ton Tripod Jack**

Operation and Maintenance Manual  
with Illustrated Parts List

2222 South Third Street  
Columbus, Ohio 43207-2402  
Phone (614) 443-7492 FAX (614) 445-3981  
[sales@columbusjack.com](mailto:sales@columbusjack.com)

9/22/2010

**1.0 Introduction**

This manual is issued as a basic operation and maintenance manual covering the Model 50J25178-10E1, 10 Ton Tripod Jack manufactured by Columbus**JACK**/Regent, 2222 S. Third St., Columbus, Ohio 43207, USA, phone number (614) 443-7492, FAX number (614) 445-3981.

To derive maximum service, it is recommended that personnel have an understanding of the equipment before attempting to operate the jack. It is mandatory that the operating procedures herein be followed.

**2.0 Specifications**

Capacity	10 Tons
Minimum Height	54 Inches
Hydraulic Lift	26 Inches
Screw Extension	18 Inches
Maximum Height	98 Inches
Operating Pressure	2080 Psi
Relief Valve Pressure	2290 Psi
Estimated Weight	340 Lbs

**3.0 Safety Information**

***Make sure all personnel involved with this tripod jack read and understand these instructions before using jack.***

**WARNING:** Each jack is operated independently and aircraft must be raised evenly to provide stability. Failure to use safe jacking practices may result in equipment damage and injury to personnel. Personnel not involved in jacking the aircraft must remain clear of the immediate area. Other work should not be performed until jacking is completed and aircraft is stabilized. Do not work under suspended loads unless required. Failure to follow strict safety precautions may result in equipment damage and injury or death to personnel. When jacking operations are completed and aircraft is stabilized, necessary personnel may complete required maintenance actions under aircraft.

The jack is designed to lift only vertical loads with a maximum weight of 10 tons (20,000 pounds). Do not use jack for lifts exceeding the weight or design limits. Failure to comply can result in injury or death to personnel and/or severe damage to the jack and aircraft.

Casters will carry only weight of jack. Ensure casters compress under aircraft load to prevent injury to personnel and equipment damage.

#### **4.0 System Bleed Procedure**

- 4.1 Break hydraulic line at base of cylinder.
- 4.2 Operate hand pump until oil comes out freely with no air bubbles. Retighten hydraulic line at base of cylinder.
- 4.3 Raise ram approximately six (6) inches with hand pump.
- 4.4 Open release valve.
- 4.5 If ram fails to raise, repeat steps 4.1 thru 4.2 until all air is removed and ram is able to raise upon using hand pump.

#### **5.0 Pre-Operation Procedure**

- 5.1 Perform visual inspection, by checking for oil leakage.
- 5.2 Check for loose, damaged or missing parts.
- 5.3 Check oil level.

#### **6.0 Lifting Procedures**

- 6.1 Extension screw should be screwed down and ram should be fully retracted.
- 6.2 Position jack under load lifting point. Verify that jack footpads will rest on level concrete foundation. If not on concrete, it may be necessary to place a flat steel plate under footpads to distribute jack bearing pressure.
- 6.3 Unscrew the extension screw as required.
- 6.4 Close release valve.
- 6.5 Operate pump to extend ram until contact is made with load lift point and extension screw adapter, with no pressure applied.
- 6.6 Rotate jack approximately 15° in any direction to minimize jack movement when load is applied to casters.
- 6.7 Operate pump to extend ram until the footpads touch the ground.
- 6.8 Extend ram to desired height. Set locknut.

**WARNING: MAINTAIN APPROXIMATE ONE (1) INCH CLEARANCE BETWEEN LOCKNUT AND MATING SURFACE DURING RAISING AND LOWERING OF RAM.**

**6.0 Lifting Procedures** (Continued)

- 6.9 Screw locknut down against cylinder head and ram to mechanically secure the lifted load.
- 6.10 Open release valve to release hydraulic pressure.

**7.0 Lowering Procedure**

- 7.1 Close release valve.
- 7.2 Operate pump to raise ram until locknut is free to rotate.
- 7.3 Slowly open jack release valve and allow ram to fully retract.

**Note:** Speed of lowering is controlled by how far release valve is open.

**WARNING: MAINTAIN APPROXIMATE ONE (1) INCH CLEARANCE BETWEEN LOCKNUT AND MATING SURFACE DURING RAISING AND LOWERING OF RAM.**

- 7.4 Lower extension screw completely.

**8.0 Relief Valve Setting** (Figure 2)

- 8.1 Position jack under a jack tester. Partially extend the ram.
- 8.2 Remove vent assembly (Item 16) and plug (Item 35).
- 8.3 Insert an 18 inch screwdriver into plug hole and align with safety valve assembly (Item 3).
- 8.4 Operate hand pump and verify that safety valve is set at 10 - 11 tons. Increase pressure setting by using screwdriver to adjust safety valve screw clockwise. To decrease pressure setting, adjust safety valve screw counterclockwise.

**CAUTION: USE CARE NOT TO SET VALVE MORE THAN 10% ABOVE RATED CAPACITY.**

**WARNING: DO NOT EXCEED 11 TONS.**

- 8.5 Remove screwdriver and reinstall vent assembly and plug.

**9.0 Special Maintenance Instructions**

There are no special maintenance instructions for this jack.

**10.0 Shop Aids Available**

Contact Columbus**JACK**/Regent Sales for any shop aids.

**11.0 Overhaul Kits Available**

Seal Kit	SKTES3-4
Repair Kit	TES3-4

**12.0 How to Locate and Remedy Trouble**

If operational troubles are encountered, refer to the Trouble Shooting Chart which lists the most commonly occurring problems and gives information which will facilitate location of trouble source and determination of remedial action.

**MODEL 50J25178-10E1  
10 TON TRIPOD JACK  
PAGE -5-**

**TROUBLESHOOTING CHART**

<b>TROUBLE</b>	<b>PROBABLE CAUSE</b>	<b>REMEDY</b>
Jack will not rise	Open pump release valve. Ball not seated; oil passing back into reservoir.	Close release valve firmly. If necessary, reopen release valve, pump rapidly to flush out foreign matter. Close release valve.
	Open suction valve. Ball not seated; oil passing back into reservoir.	Pump rapidly to flush system
	Open discharge valve. Ball not seated; oil passing back into pump chamber.	Pump rapidly to flush system.
	Sticking suction valve	Pump rapidly to flush system.
	Clogged screen	Remove and clean
	Lack of oil	Refill - Check for leaks
	Air under ram	Bleed system
	Leaks in hose assembly	Retighten or repair
Jack will not raise capacity load	Faulty pump safety valve (set too low or it leaks)	Reset adjusting screw
	Faulty pump safety valve	Reset adjusting screw
	High pressure leaks at joints, plugs or tubing	Retighten or repair
	Leaky discharge valve	Replace defective parts or rework valve seat in pump base
	Leaky ram O-ring packing	Replace packing
Jack will not raise to full height	Leaky pump release	Tighten
	Lack of oil	Refill reservoir; check system for leaks
	Sticking suction valve	Pump rapidly to dislodge
	Clogged screen	Clean screen
Jack rises and falls during each stroke	Closed air vent	Open air vent
	Leaky discharge valve	Replace defective parts or rework valve seat in pump base
Jack will not hold up load	Leaky release valve	Replace defective parts
	Leaky discharge valve	Replace defective parts or rework valve seat in pumping base
	Leaky ram o-ring packing	Replace packing
	Leaky safety valve	Replace defective parts or rework valve seat in pump base
	Leaks in oil line	Retighten or repair
	Safety ram lock nut not in right place	Loosen screw and rotate nut down against bearing

**MODEL 50J25178-10E1  
10 TON TRIPOD JACK  
PAGE -6-**

**TROUBLESHOOTING CHART**

<b>TROUBLE</b>	<b>PROBABLE CAUSE</b>	<b>REMEDY</b>
Jack will not lower the load	Safety ram lock nut not in right place	Loosen screw and rotate nut to top of ram and tighten screw
	Broken pump release valve	Replace defective parts as needed
	Bent ram	Rework ram or replace entire lift unit
Jack will not completely close	Safety ram lock nut not in right place	Loosen screw and rotate nut to top of ram and tighten screw
	Damaged ram	Rework ram or replace entire lift unit
	Air under ram	Bleed system
	Restricted oil passage	Disconnect one end of hose and pump handle rapidly to flush
Excessive pressure required to work handle	Handle position in relation to piston requires adjustment	Disconnect one end of hose and pump handle rapidly to flush
	Restricted oil passage	Disconnect one end of hose and pump handle rapidly to flush
Handle stroke partially ineffective	Sticking intake valve	Open pump release and pump rapidly to flush system
	Clogged screen	Clean screen
	Closed air vent	Open air vent

# ColumbusJACK/Regent

Model 50J25178-10E1  
 10 Ton Tripod Jack  
 Page 1 of 2  
 Figure 1

FIG. & ITEM NO.	PART NUMBER	DESCRIPTION	UNITS PER ASS'Y
<b>1-</b>	<b>50J25178-10E1</b>	<b>10 Ton Tripod .....</b>	<b>Ref.</b>
-1	50D25184	Cylinder Ram .....	1
-2	51D7138	Pump Assembly .....	1
-3	50D25181	Ram Assembly .....	1
-4	50B25197	Upper Leg .....	3
-5	50B25235	Leg Extension .....	3
-6	50B25213	Brace #1 .....	6
-7	50B25211	Brace #2 .....	6
-8	Not Used		
-9	Not Used		
-10	Not Used		
-11	Not Used		
-12	Not Used		
-13	AN350-1032	Wing Nut .....	1
-14	48A7878-4	Rod-Pointer .....	1
-15	53D6830	Foot Assembly .....	3
-16	270AS204-2	Clamp Assembly .....	1
-17	49B6450-4	Tube Assembly .....	1
-18	JC11636	Pin Blanket .....	1
-19	42A7530	Adapter .....	1
-20	49B6568	Hose Assembly .....	1
-21	43A13906	Connector Assembly, Male .....	1
-22	Not Used		
-23	MS90726-114	Hex Head Cap Screw .....	6
-24	MS21044-N8	Hex Nut, Self-Locking .....	15
-25	MS35207-261	Screw, Pan Head .....	1
-26	Not Used		
-27	MS90726-125	Hex Head Cap Screw .....	6
-28	AN8-16A	Hex Head Cap Screw .....	3
-29	Not Used		
-30	59J6185-1	Chain .....	1
-31	50A25156	Nameplate .....	1
-32	AN535-2-2	Drive Screw .....	4
-33	42A13047-3	Decal, 10 Ton .....	1
-34	50C25159	Assembly Decal .....	1
-35	50B25162	Decal, Rise Indicator .....	1



# ColumbusJACK/Regent

Model 50J25178-10E1  
10 Ton Tripod Jack  
Page 2 of 2  
Figure 1

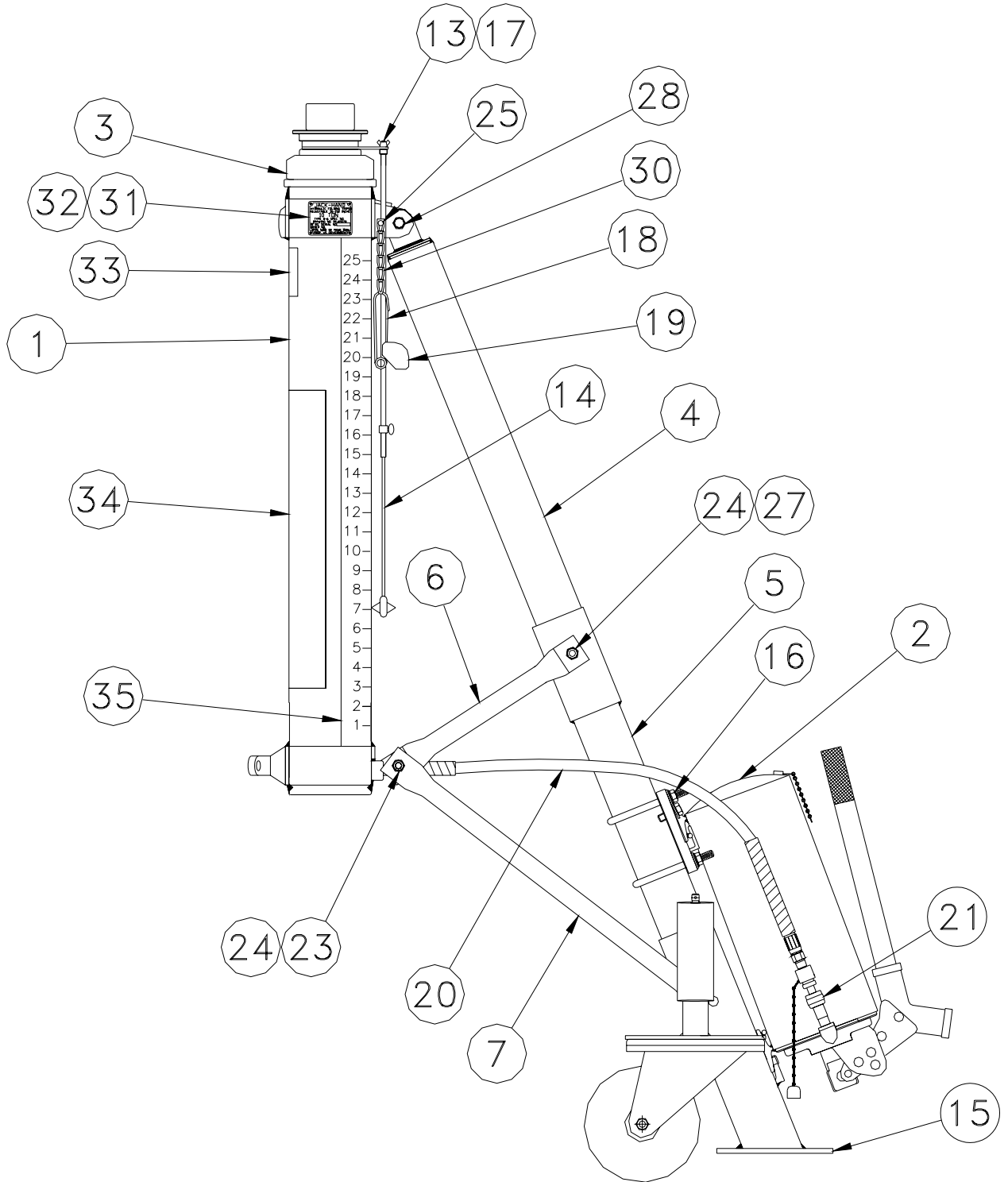

# ColumbusJACK/Regent

Model 50J25178-10E1  
 10 Ton Tripod Jack  
 Page 1 of 3  
 Figure 2

FIG. & ITEM NO.	PART NUMBER	DESCRIPTION	UNITS PER ASS'Y
<b>2-</b>	<b>51D7138</b>	<b>Pump Assembly .....</b>	<b>Ref.</b>
-1	50C25220-2	Reservoir Weldment.....	1
-2	52D6861	Body, Pump.....	1
-3	43A12192-3	Relief Valve Assembly.....	1
-3.1	42A12999	Body.....	1
-3.2	42A13000	Relief Valve.....	1
-3.3	42A13001	Spring.....	1
-3.4	42A13002	Set Screw.....	1
-4	48C7860	Socket, Pump Handle .....	1
-5	48B7861	Handle, Pump.....	1
-6	52B6863	Piston, Pump .....	1
-7	42A13017	Pin, Pump Piston.....	1
-8	42A13016	Roller, Piston Pin.....	1
-9	43A12196	Pin Assembly.....	1
-10	42A13004	Spring .....	1
-11	42A13003	Spring, Intake Valve .....	1
-12	48B7863-2	Backup Ring, Teflon.....	1
-13	52B6864	Nut, Packing.....	1
-14	48A7858	Washer.....	6
-15	43A12191-3	Relief Valve Assembly.....	1
-15.1	42A13009	Body.....	1
-15.2	42A13010	Spring.....	1
-15.3	42A13011	Relief Valve.....	1
-15.4	42A13055	Set Screw.....	1
-16	50B7763	Air Vent Assembly.....	1
-17	43A12197	Chain Assembly .....	1
-18	42A13025	Gasket, Pump Body .....	1
-19	48A7880	Felt Wiper .....	1
-20	48A7866	Retaining Ring.....	1
-21	43A13905	Connector Assembly, Female.....	1
-22	42A13022	Nut, Release Stem .....	1
-23	42A13021	Packing, Release Stem.....	1
-24	42A12998	Release Valve Assembly .....	1
-25	450A4276	Socket Head Cap Screw .....	2
-26	378-16060	Socket Head Cap Screw .....	4
-27	450A5313	Chain .....	AR
-28	MS28775-218	O-Ring.....	1
-29	MS35206-261	Pan Head Screw .....	1
-30	MS21318-41	Drive Screw .....	3
-31	MS19059-2417	Ball.....	1
-32	MS19059-2414	Ball.....	2
-33	MS27769U2	Pipe Plug .....	2
-34	MS27769U3	Pipe Plug .....	1
-35	488-00006	Pipe Plug.....	1
-36	43A12145	Decal, Air Vent Instructions.....	1
-37	D2421	Screen, Brass.....	1
-38	42A13047-3	Decal, 10 Ton Capacity.....	1

# ColumbusJACK/Regent

Model 50J25178-10E1  
10 Ton Tripod Jack  
Page 2 of 3  
Figure 2

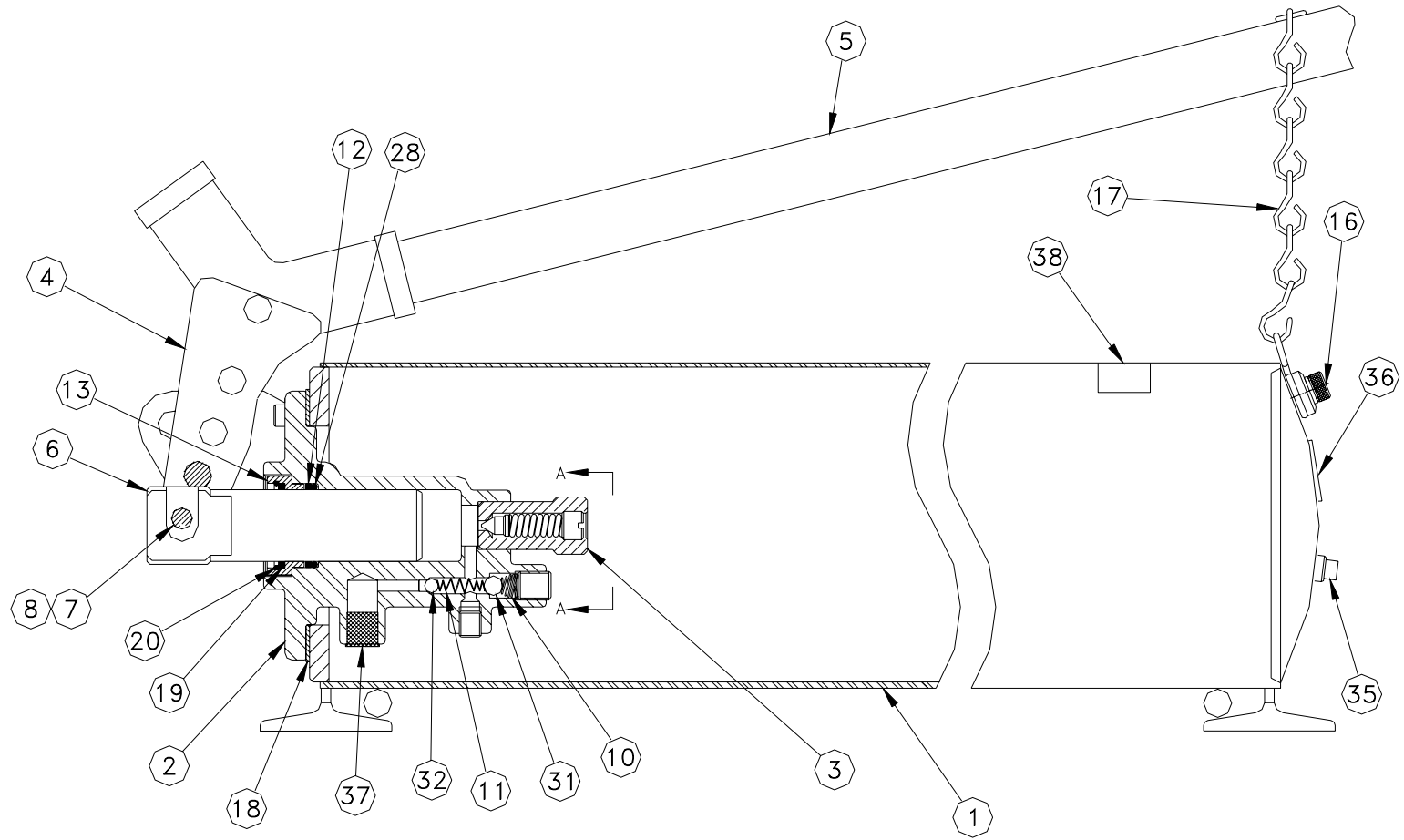

# ColumbusJACK/Regent

Model 50J25178-10E1  
10 Ton Tripod Jack  
Page 3 of 3  
Figure 2

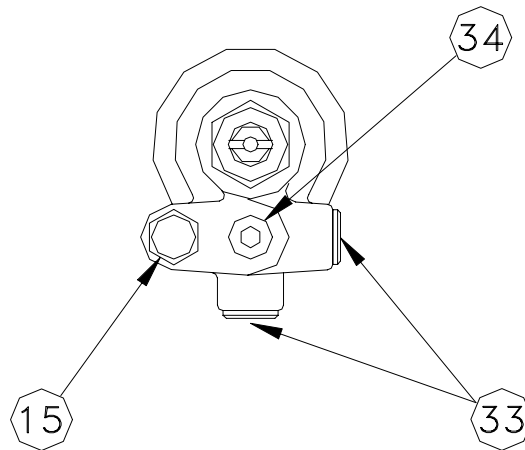
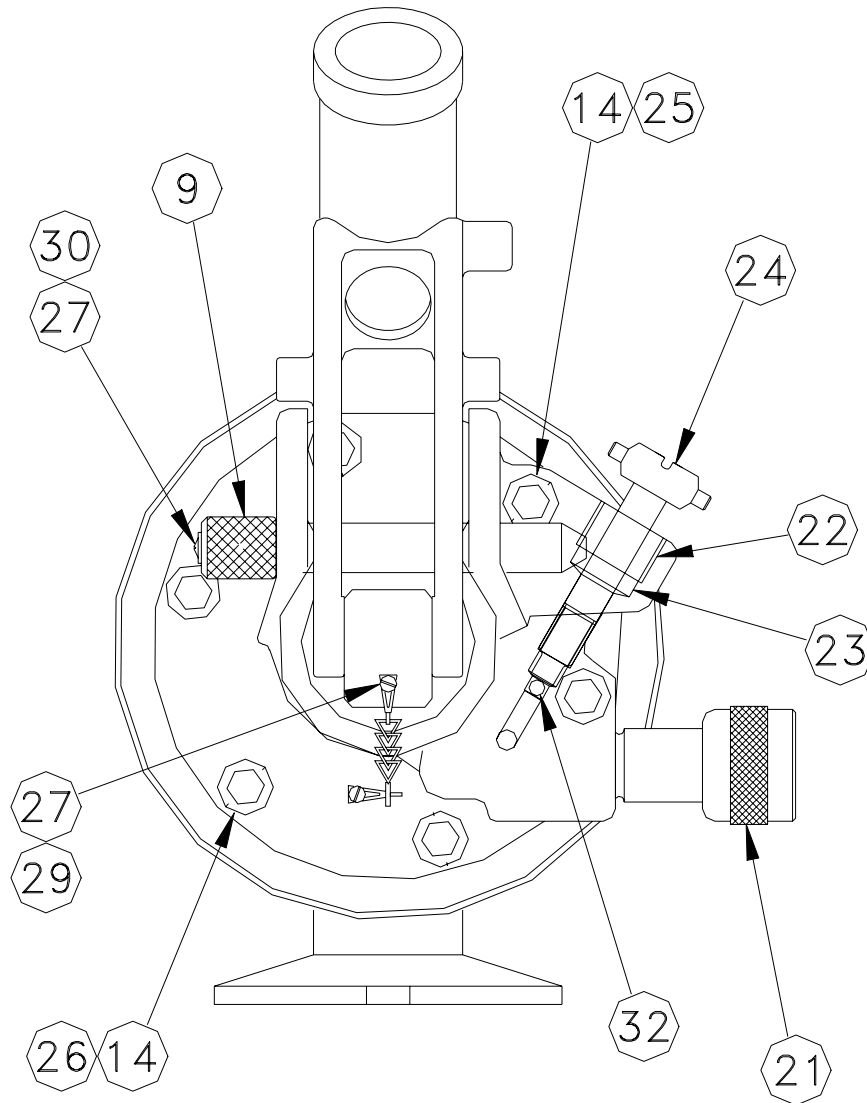

VIEW A-A

# ColumbusJACK / Regent

Model 50J25178-10E1  
 10 Ton Tripod Jack  
 Page 1 of 2  
 Figure 3

FIG. & ITEM PART NUMBER NO.	DESCRIPTION	UNITS PER ASS'Y
<b>3- 50D25181</b>	<b>Ram Assembly .....</b>	<b>Ref.</b>
-1 50C25205	Ram and Nut Assembly .....	1
-2 50C25201	Extension Screw .....	1
-3 50B25168	Bearing, Upper .....	1
-4 51B7332	Locknut.....	1
-5 50B25239	Collar, Rise Indicator.....	1
-6 43A12190-4	Locknut Assembly.....	1
-7 50B25259	Retainer.....	1
-8 56B6129	Socket Assembly .....	1
-9 43A12189-2	Key Assembly .....	1
-10 50A25187	Pin, Ram .....	1
-11 50B25175-2	Backup Ring.....	1
-12 MS28775-338	O-Ring.....	1
-13 50B25222	Bearing, Ram .....	1
-14 AN510-4-6	Screw, Flat Head .....	4
-15 AN565A10H-6	Set Screw.....	1
-16 50B25152	Bearing, Lower .....	1
-17 42A12988	Plunger.....	1
-18 42A12989	Spring.....	1

# ColumbusJACK / Regent

Model 50J25178-10E1  
10 Ton Tripod Jack  
Page 2 of 2  
Figure 3

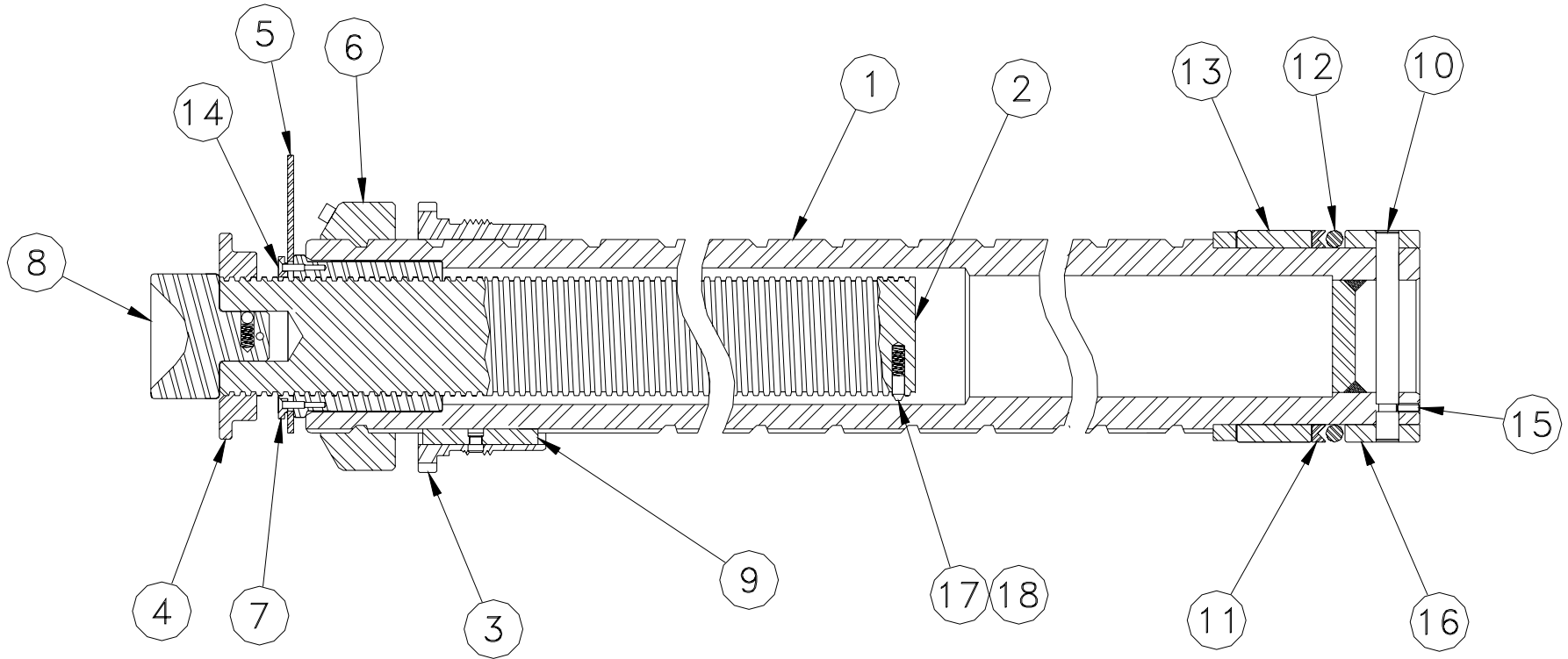

# ColumbusJACK/Regent

Model 50J25178-10E1  
 10 Ton Tripod Jack  
 Page 1 of 2  
 Figure 4

FIG. & ITEM NO.	PART NUMBER	DESCRIPTION	UNITS PER ASS'Y
<b>4-</b>	<b>53D6830</b>	<b>Foot Assembly.....</b>	<b>Ref.</b>
-1	53C6832	Caster Mount Weldment .....	1
-2	53H6831	Foot Assembly.....	1
-3	AN320-6	Hex Nut, Cast.....	1
-4	AN380-3-3	Cotter Pin .....	1
-5	AN960-616	Flat Washer .....	1
-6	M-54	Spring .....	1
-7	MS24380-6SU	Caster, Swivel .....	1
-8	MS35292-110	Hex Head Cap Screw.....	4
-9	MS35338-48	Lockwasher .....	4
-10	MS51968-14	Hex Nut .....	4

# ColumbusJACK/Regent

Model 50J25178-10E1  
10 Ton Tripod Jack  
Page 2 of 2  
Figure 4

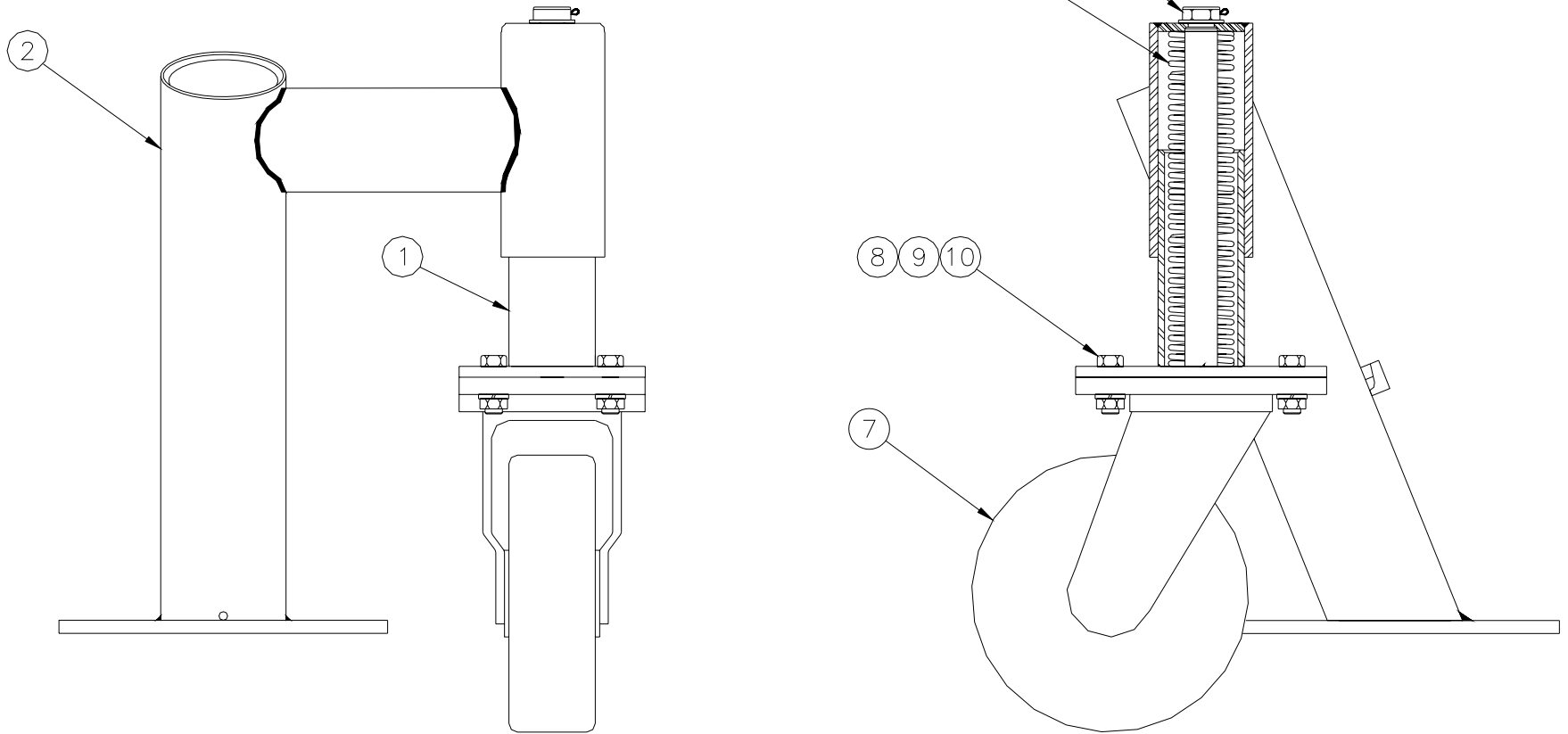



# ColumbusJACK/Regent

Model 50J25178-10E1  
 10 Ton Tripod Jack  
 Page 1 of 2  
 Figure 5

FIG. & ITEM NO.	PART NUMBER	DESCRIPTION	UNITS PER ASS'Y
<b>5-</b>	<b>270AS204-2</b>	<b>Clamp Assembly.....</b>	<b>Ref.</b>
-1	NAS3105C20-18	U-Bolt.....	2
-2	270AS205-1	Plate.....	1
-3	MS35338-46	Lockwasher.....	1
-4	MS90725-60	Hex Head Cap Screw.....	1
-5	MS27183-13	Flat Washer.....	1
-6	MS27183-11	Flat Washer.....	4
-7	MS35338-45	Lockwasher.....	4
-8	MS35691-15	Hex Nut, Jam.....	4

# ColumbusJACK/Regent

Model 50J25178-10E1

10 Ton Tripod Jack

Page 2 of 2

Figure 5

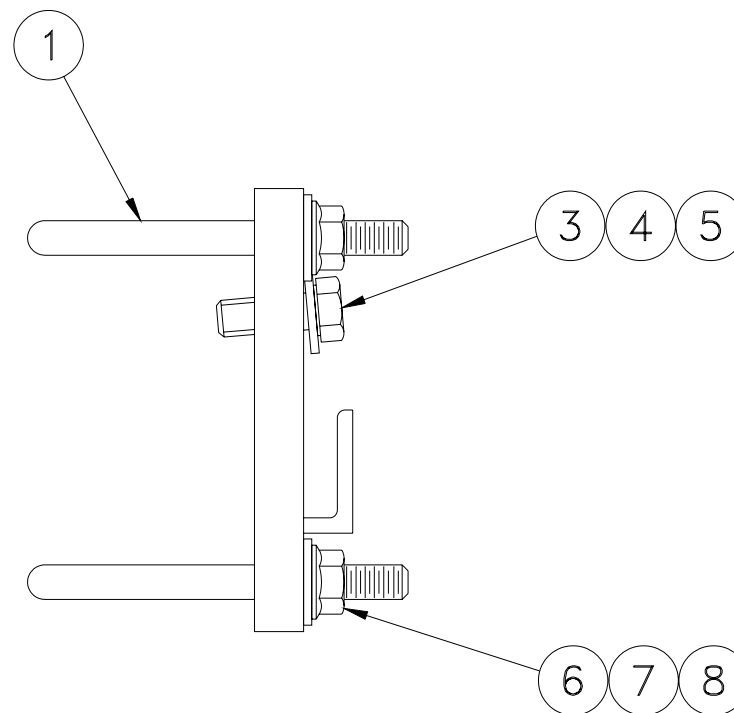
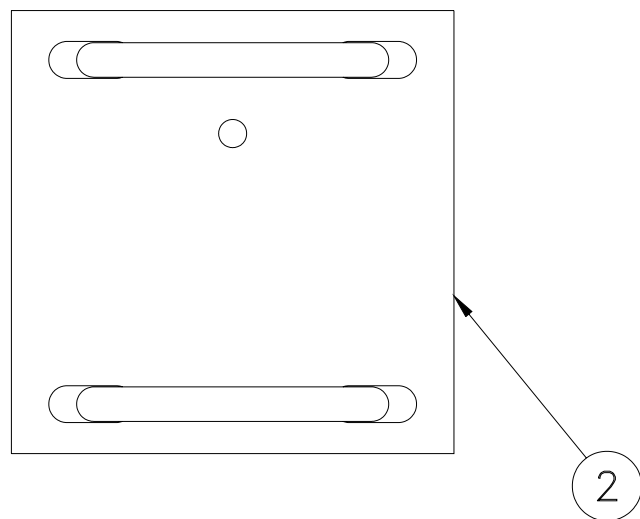

# Appendix



# **ROUTINE JACK MAINTENANCE BULLETIN**

RJM 102

1 OF 1

## **TO PROVIDE COMPLETE INFORMATION ON SERVICING ColumbusJACK/REGENT QUALITY GROUND HANDLING EQUIPMENT**

### **PROCEDURE FOR WINTERIZATION OF HYDRAULIC AIRCRAFT JACKS**

The following procedures should be utilized for optimum operational characteristics when using jacks at various temperature extremes:

- 1) Above 0°F (-18°C)

Use MIL-H-5606, or equal, with no further additive required.

- 2) At 0°F (-18°C) to -20°F (-29°C)

Use a mixture of 75% MIL-H-5606, or equal, and 25% kerosene.

- 3) Below -20°F (-29°C)

Use a mixture of 50% MIL-H-5606, or equal, and 50% kerosene.

Due to most company, safety, or union regulations which restrict employees from working out-of-doors below -30°F (-34°C), there is a lack of experience beyond this point. It is permissible, however, to increase the percentage of kerosene up to 100%. As the ambient temperature increases, MIL-H-5606, should be added back to the system in the appropriate mixture.

The air supply should be clean and dry. At -30°F (-34°C), the air pump will start to react sluggishly and continue to operate less efficiently as the temperature decreases when a normal air supply is used. The problem can be eliminated by using a dry nitrogen source of sufficient capacity.

To ease the operation of the locknut(s) and screw extension, use "Never Freeze" by Snap-On, or equal, and apply liberally to the thread surfaces.



# **ROUTINE JACK MAINTENANCE BULLETIN**

RJM 116

1 OF 1

**TO PROVIDE COMPLETE INFORMATION ON SERVICING  
ColumbusJACK/REGENT QUALITY GROUND HANDLING EQUIPMENT**

## **SCREW EXTENSION USAGE**

When using a jack that has a screw extension, it is advisable that the screw extension be extended as far as possible, and still have the jack roll under the jacking point. If the screw extension is not properly extended, the aircraft may not be able to be raised to the desired height.

A periodic check should be made to the screw extension to ensure that the stop is operating properly to prevent over-extension. To do this, rotate the screw extension counterclockwise until it stops rotating. **DO NOT FORCE THE SCREW EXTENSION BEYOND THIS POINT**. If the screw extension does not stop rotating, remove it and repair the stop. **DO NOT USE WITHOUT THE SCREW EXTENSION STOP WORKING PROPERLY, AS THE JACK COULD FAIL WITH AN OVER-EXTENDED SCREW EXTENSION.**



# **ROUTINE JACK MAINTENANCE BULLETIN**

RJM 147

1 OF 1

## **TO PROVIDE COMPLETE INFORMATION ON SERVICING ColumbusJACK/REGENT QUALITY GROUND HANDLING EQUIPMENT**

### **RECOMMENDED ANNUAL JACK CERTIFICATION PROCEDURE**

To ensure proper operation of all aircraft hydraulic jacks, it is important that at a minimum, each jack is certified on an annual basis. The following procedure is provided as an aid to the certification process.

- 1) With no external load applied to the jack, fully close release valve and fully extend ram(s) to verify function and the absence of external hydraulic leakage.
- 2) Open release valve and verify ram(s) retract fully.
- 3) Position jack under jack tester.
- 4) Close release valve, and fully extend all ram(s). Open release valve:
  - a) Single Stage Cylinder - Lower ram 2-4 inches.
  - b) Multi-Stage Cylinder - Lower smallest ram **only** approximately one inch.
- 5) Pressurize the jack against the jack tester. Using a calibrated pressure gauge on either the jack or the jack tester, monitor the pressure until the capacity (operating pressure) of the jack is reached.
- 6) With the jack pressurized against the jack tester, hold in this position for 3 minutes. Verify that the jack pressure has not decreased, indicating internal leakage.
- 7) Open the release valve to relieve jack pressure against the jack tester.
- 8) Set the safety relief valve per jack operation and maintenance manual.



# ROUTINE JACK MAINTENANCE BULLETIN

RJM 149

1 OF 1

## TO PROVIDE COMPLETE INFORMATION ON SERVICING ColumbusJACK/REGENT QUALITY GROUND HANDLING EQUIPMENT

### TEFLON BACKUP RING INSTALLATION PROCEDURE

When installing new Teflon backup rings on a ram or piston of any jack model, the following procedure should be observed to ensure correct installation of the ring. When installing a new backup ring, the corresponding o-ring should always be replaced also.

- 1) Cut existing o-ring and Teflon backup ring.
- 2) Clean and visually inspect the groove in the ram or piston for any nicks, scratches or score marks, which could cut the o-ring and backup ring during installation.
- 3) Check to ensure backup ring is clean and not damaged.
- 4) Set backup ring on a flat metal surface.
- 5) Using a propane torch, heat backup ring in a circular motion until backup ring is equally softened and pliable or flexible.
- 6) Carefully pick-up the **HOT** Teflon backup ring off the **HOT** metal plate and stretch the ring enough to fit over the end of the ram (piston). **NOTE: Make sure the "V" cup portion of the backup ring will face the o-ring.** (See figure)
- 7) If backup ring does not return to size after cooling, re-heat backup ring while on the part, and cool quickly with a cold, wet towel or rag.
- 8) Check to ensure o-ring is clean and not damaged.
- 9) Carefully stretch o-ring over the end of the ram (piston). Ensure that the o-ring and the "V" cup of the backup ring are facing each other. (See figure)

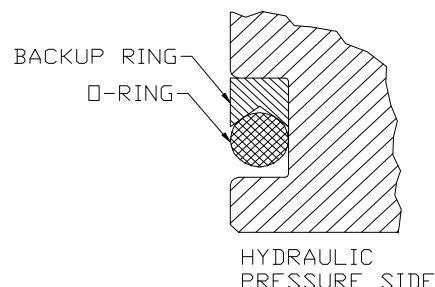



# **ROUTINE JACK MAINTENANCE BULLETIN**

RJM 170

1 OF 1

## **TO PROVIDE COMPLETE INFORMATION ON SERVICING ColumbusJACK/REGENT QUALITY GROUND HANDLING EQUIPMENT**

### **SUGGESTED PREVENTATIVE MAINTENANCE FOR JACKS**

The following Preventative Maintenance Schedule is provided as a guide to insure that hydraulic aircraft jacks are always ready for operation. The time intervals listed are a general recommendation only. The actual interval used should include factors for the climatic conditions in which the equipment is stored and the frequency of equipment use.

#### Prior to Operation

1. Inspect for damaged or missing components.
2. Inspect for oil leakage and proper fluid level.
3. Inspect screw extension for mechanical stop.
4. Inspect all snap rings for engagement into grooves.
5. Inspect jack adapter for damage.

#### Every 6 Months

1. Inspect for worn snap ring grooves.
2. Change hydraulic filters if applicable.
3. If jack has not been used regularly, cycle jack without load.
4. Grease all lube fittings with a general purpose grease.
5. Wipe down ram(s) and screw extension with hydraulic oil.

#### Every 12 Months

1. Calibrate pressure gauge if applicable per RJM 173.
2. Perform "Recommended Annual Jack Certification Procedure" per RJM 147.





# **ROUTINE JACK MAINTENANCE BULLETIN**

RJM 171

1 OF 1

**TO PROVIDE COMPLETE INFORMATION ON SERVICING  
ColumbusJACK/REGENT QUALITY GROUND HANDLING EQUIPMENT**

## **RECOMMENDED HYDRAULIC OILS**

The following hydraulic oils are recommended for use in all ColumbusJACK/Regent products, though any oil compatible with Buna-N seals may be used. Proper oil level should be .5 to 1 inch below the fill port when all rams are collapsed.

Exxon/Mobil Aero HF (MIL-5606)  
Exxon/Mobil DTE-11, -15  
Phillips 66 X/C 5606  
Royco 783 (Anderol) (MIL-PRF-6083)  
Shell Tellus 10, 15  
Shell Aerofluid 31 (MIL-PRF-83282)  
Shell Aerofluid 41 (MIL-PRF-5606)  
Texaco Regal Oil R & O (32, 46, 100, 150, 220, 320, 460)