

Model: 06-5051-6500
Contamination Monitor
(Mineral Base Fluid)

04/2005 – Rev. OR

REVISION
OR

DATE
04/2005

TEXT AFFECTED
Original release

TABLE OF CONTENTS

	<u>PAGE</u>
1.0 DESCRIPTION	1
2.0 SAFETY INFORMATION	1
3.0 PACKAGING AND STORAGE	1
4.0 TRANSPORTATION	1
5.0 ASSEMBLY	1
6.0 INSTALLATION	1
7.0 OPERATION	1
7.1 HYDRAULIC POWER UNIT FLUID MONITORING.....	1
7.1.1 Sample Valve Method.....	1
7.1.2 Inline Sensor Method.....	1
7.2 LASER CM 20.....	2
8.0 TROUBLE SHOOTING	2
9.0 TRAINING	2
10.0 MAINTENANCE	2
11.0 PROVISION OF SPARES	3
11.1 SPARE PARTS CAN BE OBTAINED FROM THE MANUFACTURER.....	3
11.2 RECOMMENDED SPARE PARTS TO BE KEPT ON HAND.....	3
12.0 IN-SERVICE SUPPORT	3
13.0 GUARANTEES/LIMITATION OF LIABILITY	3

This product can not be modified without the written approval of Tronair, Inc. Any modifications done without written approval voids all warranties and releases Tronair, Inc., its suppliers, distributors, employees, or financial institutions from any liability from consequences that may occur. Only Tronair OEM replacement parts shall be used.

1.0 DESCRIPTION

The Tronair contamination monitor is a portable test unit used to determine solid particle contamination of hydraulic fluid during hydraulic power unit operation.

Optional Kit:

Inline Sensor Kit: K-2339 (Mineral Base)

The inline sensor kit allows the operator to monitor hydraulic power unit fluid cleanliness while operating in a self cleaning mode. It also provides a sample source to monitor the cleanliness of aircraft hydraulic fluid.

2.0 SAFETY INFORMATION

See Appendix I

3.0 PACKAGING AND STORAGE

See Appendix I

4.0 TRANSPORTATION

See Appendix I

5.0 ASSEMBLY

See Appendix I

6.0 INSTALLATION

See Appendix I

7.0 OPERATION

7.1 HYDRAULIC POWER UNIT FLUID MONITORING

7.1.1 Sample Valve Method

Hydraulic fluid taken from the sample valve location is representative of the hydraulic fluid being sent to the aircraft by the hydraulic power unit. The fluid has been pressurized and filtered. What is not considered in this sampling method is any contamination added by the external pressure hose after the sample valve.

The hydraulic power unit is set-up following the step by step procedure below:

1. Reservoir selector: Hydraulic Power unit position.
2. Close and uncap sample valve.
3. Start hydraulic power unit.
4. Set flow from one to three GPM.
5. Set pressure: 100 to 200 psig.
6. Open/Close sample valve to flush by flowing approximately one (1) quart of fluid. Discard the fluid.
7. Connect contamination monitor to sample valve.
8. Open sample valve and allow hydraulic fluid to circulate through the contamination monitor for approximately 5 minutes in order to stabilize and flush out the system. By operating sample valve, adjust flow to approximately 1 - 2 quarts/minute.
9. Conduct the independent flow test (paragraph 5.2.1) to assure adequate flow through the contamination monitor.
10. Conduct sample test per paragraph 5.3 and 5.4.

7.1.2 Inline Sensor Method

The inline sensor kit allows the user to monitor the cleanliness of either the hydraulic power unit or an aircraft system.

The inline sensor kit contains the inline sensor and various adaptor fittings that enable the inline sensor to be installed at the end of the hydraulic power unit return hose ahead of the aircraft quick disconnect coupling. During installation, select the proper fittings from this kit and install the inline sensor with the flow ARROW on the sensor pointed TOWARD the return hose. After the inline sensor has been installed, it need not be removed. When not in use, assure dust caps are used.

1. Cleaning The Hydraulic Power Unit

During normal scheduled maintenance of your hydraulic power unit it is suggested the unit be **CLEANED** and tested with the contamination monitor and that the test data be maintained with the hydraulic power unit logs.

Cleaning is accomplished by connecting the hydraulic power unit pressure output hose to the return hose.

CAUTION!



- "Open" return system isolation valves prior to hydraulic power unit operation.
- Closed valves will cause the return hose to fail and may cause injury to personnel.

7.1.2 Inline Sensor Method (*continued*)

The inline sensor kit allows the user to monitor the cleanliness of either the hydraulic power unit or an aircraft system.

The inline sensor kit contains the inline sensor and various adaptor fittings that enable the inline sensor to be installed at the end of the hydraulic power unit return hose ahead of the aircraft quick disconnect coupling. During installation, select the proper fittings from this kit and install the inline sensor with the flow ARROW on the sensor pointed TOWARD the return hose. After the inline sensor has been installed, it need not be removed. When not in use, assure dust caps are used.

With the hoses connected, operate the hydraulic power unit at full flow with the unit bypass valve closed and the reservoir selector valve in the "hydraulic power unit reservoir" position.

During operation periodically open and close the bypass valve and cycle the pump flow and pressure controls. If the unit is equipped with the dual system options, the second set of hoses must also be connected together and flushed; do each set of hoses separately. The intent being to pass high velocity fluid through all systems of the hydraulic power unit so that all of the fluid is filtered and cleaned.

Just after hydraulic power unit start-up, take a cleanliness level reading with the contamination monitor and periodically take additional readings until the required cleanliness level is attained.

If during the cleaning procedure the cleanliness level reaches a plateau before the unit is fully cleaned, change your pressure filter. After installing the new pressure filter continue hydraulic power unit operation until the required level is attained.

The amount of time required to clean your hydraulic power unit is dependant on the cleanliness level of your unit, the filter beta ratio of you filter, the length of time between cleaning and the size of particulate in the fluid. Reference paragraph 4.0, fluid contamination discussion.

Frequent cleaning of your hydraulic power unit of once per year or closer intervals will assure that clean fluid is going to your aircraft.

Abbreviated Instructions:

1. Join HPU hoses.
2. Assure all return isolation valve(s) is "OPEN".
3. Operate HPU at full flow.
4. Cycle bypass valve and pump flow and pressure controls during cleaning procedure.
5. Monitor fluid cleanliness by taking periodic readings with the contamination monitor.
6. If the degree of cleanliness levels off at a higher than required plateau, change filter(s) and continue HPU operation.
7. Repeat HPU cleaning procedure on a routine basis. Once per year or closer interval.

2. Monitoring Aircraft Systems

The contamination monitor used in conjunction with the inline sensor can be used to monitor aircraft system cleanliness.

The important factor here is to make sure the unit is receiving enough flow of hydraulic fluid from the aircraft throughout the four (4) minute test.

Procedure:

Hook up the hydraulic power unit to the aircraft. Set the hydraulic power unit reservoir selector valve in either the HYDRAULIC POWER UNIT or the AIRCRAFT RESERVOIR position. Flow and pressure settings should be normal for the aircraft being tested.

With the hydraulic power unit operating, begin cycling a specific system on the aircraft, for example the flaps, while cycling this system conduct the contamination.

All aircraft can be so tested and the results cataloged. Again, the real benefit to be gained is from regular use as an effective comparator of hydraulic fluid samples that will set a trend and insight of system cleanliness relating to component wear.

7.2 LASER CM 20

See Appendix I

8.0 TROUBLE SHOOTING

See Appendix I

9.0 TRAINING

See Appendix I

10.0 MAINTENANCE

See Appendix I

11.0 PROVISION OF SPARES

11.1 SPARE PARTS CAN BE OBTAINED FROM THE MANUFACTURER

TRONAIR, Inc.
1 Air Cargo Pkwy East
Swanton, Ohio 43558 USA

Telephone: (419) 866-6301 or 800-426-6301
Fax: (419) 867-0634
E-mail: sales@tronair.com
Website: www.tronair.com

11.2 RECOMMENDED SPARE PARTS TO BE KEPT ON HAND

H-1927Printer Ribbon..... 1
H-1929Paper Roll (5) 1

12.0 IN-SERVICE SUPPORT

Contact Tronair for Technical Services and information.

13.0 GUARANTEES/LIMITATION OF LIABILITY

Tronair products are warranted to be free of manufacturing or material defects for a period of one year after shipment to the original customer. This is solely limited to the repair or replacement of defective components. This warranty does not cover the following items:

- a) Parts required for normal maintenance
- b) Parts covered by a component manufacturers warranty
- c) Replacement parts have a 90-day warranty from date of shipment

If you have a problem that may require service, contact Tronair immediately. Do not attempt to repair or disassemble a product without first contacting Tronair, any action may affect warranty coverage. When you contact Tronair be prepared to provide the following information:

- a) Product Model Number
- b) Product Serial Number
- c) Description of the problem

If warranty coverage is approved, either replacement parts will be sent or the product will have to be returned to Tronair for repairs. If the product is to be returned, a Return Material Authorization (RMA) number will be issued for reference purposes on any shipping documents. Failure to obtain a RMA in advance of returning an item will result in a service fee. A decision on the extent of warranty coverage on returned products is reserved pending inspection at Tronair. Any shipments to Tronair must be shipped freight prepaid. Freight costs on shipments to customers will be paid by Tronair on any warranty claims only. Any unauthorized modification of the Tronair products or use of the Tronair products in violation of cautions and warnings in any manual (including updates) or safety bulletins published or delivered by Tronair will immediately void any warranty, express or implied.

The obligations of Tronair expressly stated herein are in lieu of all other warranties or conditions expressed or implied. **Any unauthorized modification of the Tronair products or use of the Tronair products in violations of cautions and warnings in any manual (including updates) or safety bulletins published or delivered by Tronair will immediately void any warranty, express or implied and Tronair disclaims any and all liability for injury (WITHOUT LIMITATION and including DEATH), loss or damage arising from or relating to such misuse.**

14.0 APPENDICES

APPENDIX I Laser CM20 Manual
APPENDIX II Calibration Certificate

Parts List

When ordering Replacement Parts/Kits, please specify Model & Serial Number of your product.

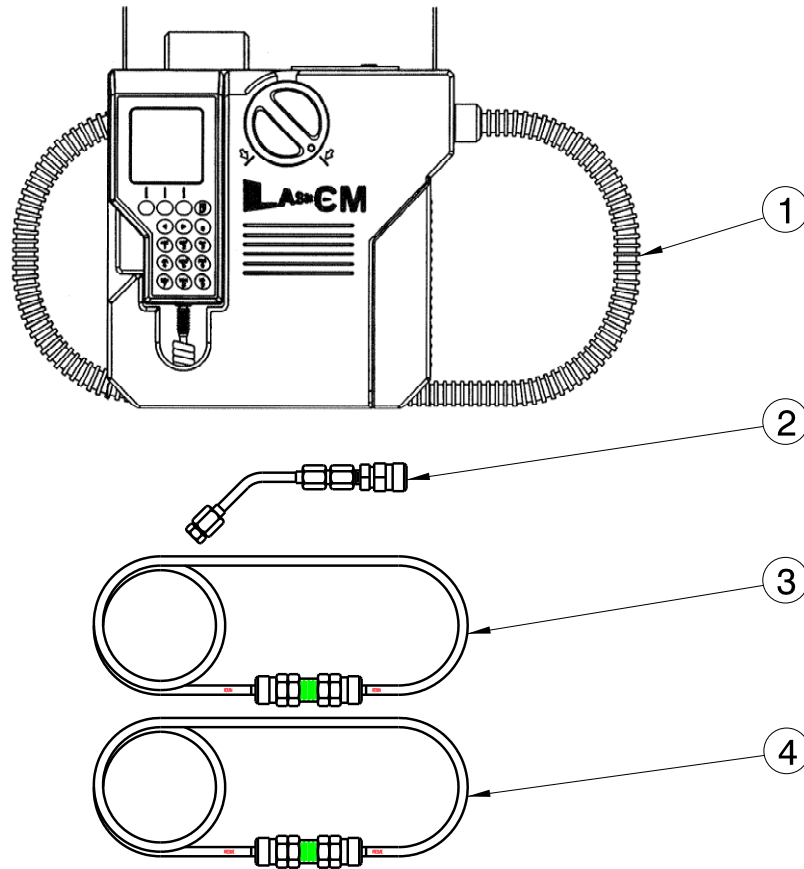

Item	Part Number	Description	Qty
1	HC-2276-01	Laser Particle Counter	1
2	Z-4417	Assembly, Sample Port Adaptor	1
3	Z-4415	Assembly, Return Hose Extension	1
4	Z-4413	Assembly, Pressure Hose Extension	1



APPENDIX I

Laser CM20 Manual

LASER CM20

LASER INFORMATION

This product contains an invisible infra-red 5mW laser.

Any dismantling of the product may result in dangerous exposure to laser radiation.

DANGER – INVISIBLE
LASER RADIATION WHEN
OPEN. AVOID DIRECT
EXPOSURE TO BEAM.

Detail of internal protective housing label, class 3, which is mounted on laser module.

This product is a class 1 laser product which complies with both USA21 CFR 1040.10 & 1040.11 and (BS) EN 608285-1

Please note that users are not required to access the laser radiation and should never do so.

LASER CM20

LASER INFORMATION

Introduction

The Parker Filtration UCC Laser CM20 Contamination Monitor represents the most up-to-date technology in solid particle contamination analysis, **and** the first truly portable monitor.

Laser CM20 is a complex instrument, but at the same time has reliability, simplicity and ease of operation designed-in.

This owner's manual has been carefully prepared to guide you, the user, step by step through how to 'get started', how to obtain measurements and how to interpret the results. Additional information relating to the 'Aggressive Fluids' monitor is also included. See page 53.

The real benefits to be gained from Laser CM20 will be achieved through regular use particularly as an effective comparator.

With a typical test taking only 2 minutes the opportunities for Laser CM20 as your standard fluid contamination monitoring instrument are considerable.

Above all, Laser CM20 has been designed to be used.

LASER CM20

CONTENTS

Contents

	Page
LASER CM20 FEATURES	2.
LASER CM20 BENEFITS	3.
ANNOTATED DIAGRAMS	4.
GETTING STARTED	8.
BASIC OPERATION	12.
BARCODE WAND	22.
HOT KEY FUNCTION	25.
ADDITIONAL FEATURES	32.
DATA INTERPRETATION	33.
COMPONENT CLEANLINESS GUIDELINES	38.
ISO CONTAMINATION CHARTS	39.
HYDRAULIC CIRCUIT DIAGRAM	42.
LOGIC DIAGRAM	43.
REPEATABILITY AND CALIBRATION	43.
LASER CM20 DIAGNOSTICS	44.
LASER CM20 REAR PANEL	47.
LASER CM20 SPECIFICATIONS	48.
ORDERING INFORMATION	50.
OPERATION CHECK LIST	51.
RE-CHARGEABLE BATTERY PACK	52.
'AGGRESSIVE FLUIDS'	54.

Features

Test Time:	2 minutes.
Repeat Test Time:	Every 2 minutes.
Principle of Operation:	Optical scanning analysis and measurement of actual particulates.
Particle counts:	2+, 5+, 15+, 25+, 50+ and 100+ microns.
International codes:	ISO 7-22 NAS 0-12
Data entry:	32 character two line dot matrix LCD. Full alpha numeric entry facility on keypad.
Data retrieval:	Memory access gives test search facility.
Calibration:	By accepted on-line methods confirmed by the relevant International Standard Organisation procedures.
Re-calibration:	Consult Parker Filtration UCC.
Max. working pressure:	420 bar.
Max. flow rate:	400 l/min when used with System 20 Sensors. Higher with Single Point Sampler (Consult Parker Filtration UCC).
Working Conditions:	Laser CM20 will operate with the system working normally.
Memory store:	300 test (scrolling memory) capacity.
Computer compatibility:	Interface via RS 232 connection @ 9600 baud rate.
Portability:	Only 8 kg. Laser CM20 has its own battery pack.
Power requirement:	Battery powered or via the 12vDC input.
System connection:	Via System 20 Inline Sensors or the Single Point Sampler.
Printer facility:	Integral 16 column printer for hard copy data.
Leak free sampling:	System 20 Sensors ensure sealed fluid extraction and no contamination ingress.
Certification:	This product complies with all relevant EC declarations of conformity.
Re-chargeable Battery:	Standard.
Laser CM20 Cover:	Weatherproof cover. (Standard)
Handset Cover:	Weatherproof cover. (Optional Extra)

FAIL SAFE FEATURES

Special 'Diagnostics' are incorporated into the Laser CM20 micro processor control to ensure effective testing.

Circuitry:	Incorporates an internal diagnostic programme to ensure integrity of results.
Adequate flow:	Flow test facility ensures adequate flow.
Adverse conditions:	On-board trace heating enabling testing in adverse conditions can be offered as an optional extra.

DATA MANAGEMENT

A specially designed DATUM software package is supplied to enable downloading of test results onto a computer.

Benefits

- Routine contamination monitoring of oil systems with Laser CM20 saves time and saves money.
- Contamination monitoring is now possible while machinery is working – Laser CM20 saves on production downtime.
- Instant, accurate results are available to international standards in hard copy form. That means system maintenance decisions can be taken immediately.
- Laser CM20 ensures that machinery hydraulic systems are tested in manufacture to ISO cleanliness standards.
- Data entry allows individual equipment test log details to be recorded.
- Data retrieval of test results from memory via hand set display.
- Data graphing of up to 30 test results can be selected for integral printing.
- Automatic test cycle logging of up to 300 tests can be selected via hand set display.
- User friendly instrument improves familiarity and awareness of service and maintenance personnel.
- Manufactured from light-weight Lexan expanded structural foam which is both durable and strong.
- Totally portable, can be used as easily in the field as in the laboratory.
- Computer interfacing available for downloading data on to compatible computer, through Laser CM20's RS232 serial port @ 9600 baud rate.
- Internal diagnostic feature ensures Laser CM20 will work accurately and reliably.
- Supplied in an Astraboard carrying case.
- Automatic calibration reminder.

Monitor – Front View

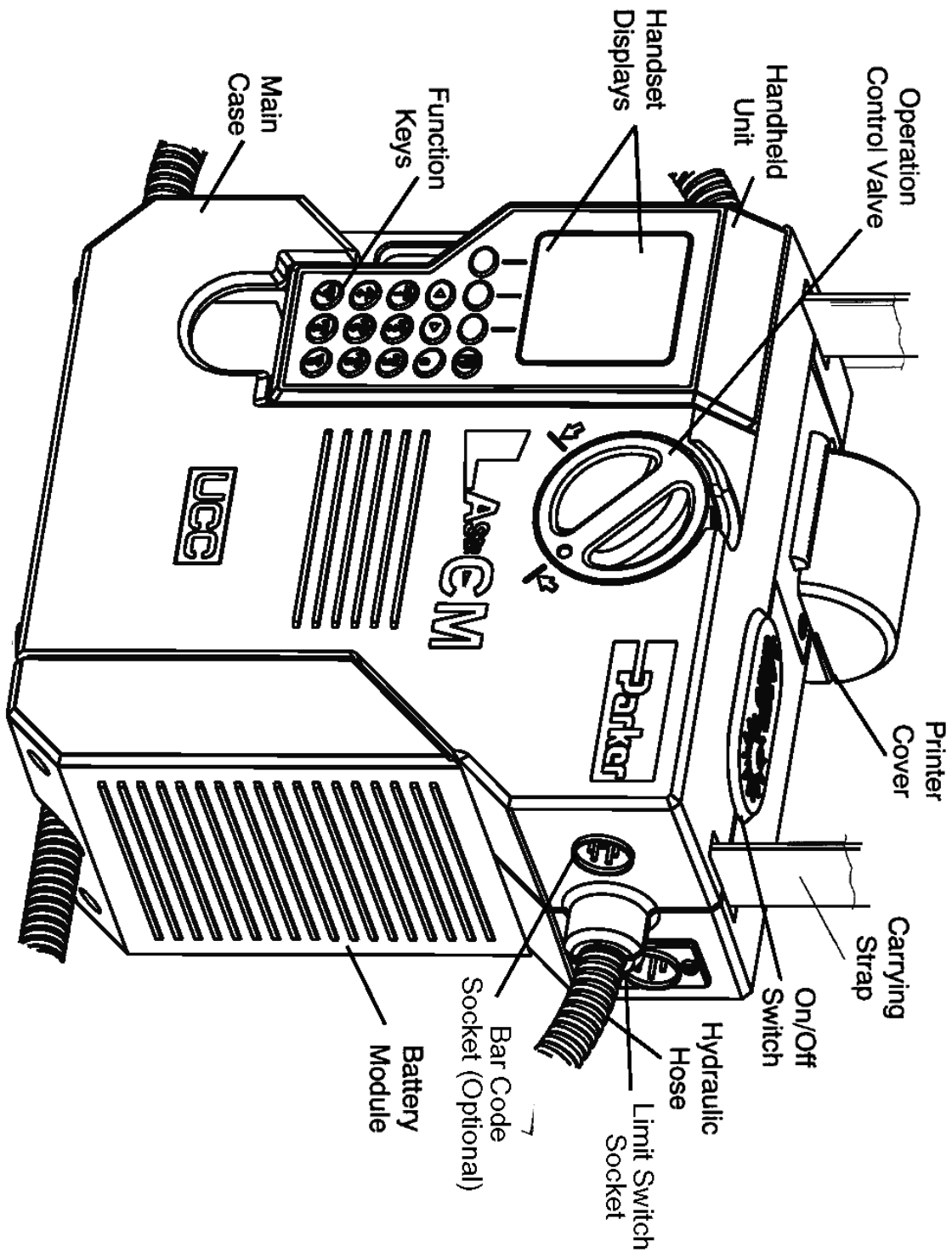

Monitor – Rear View

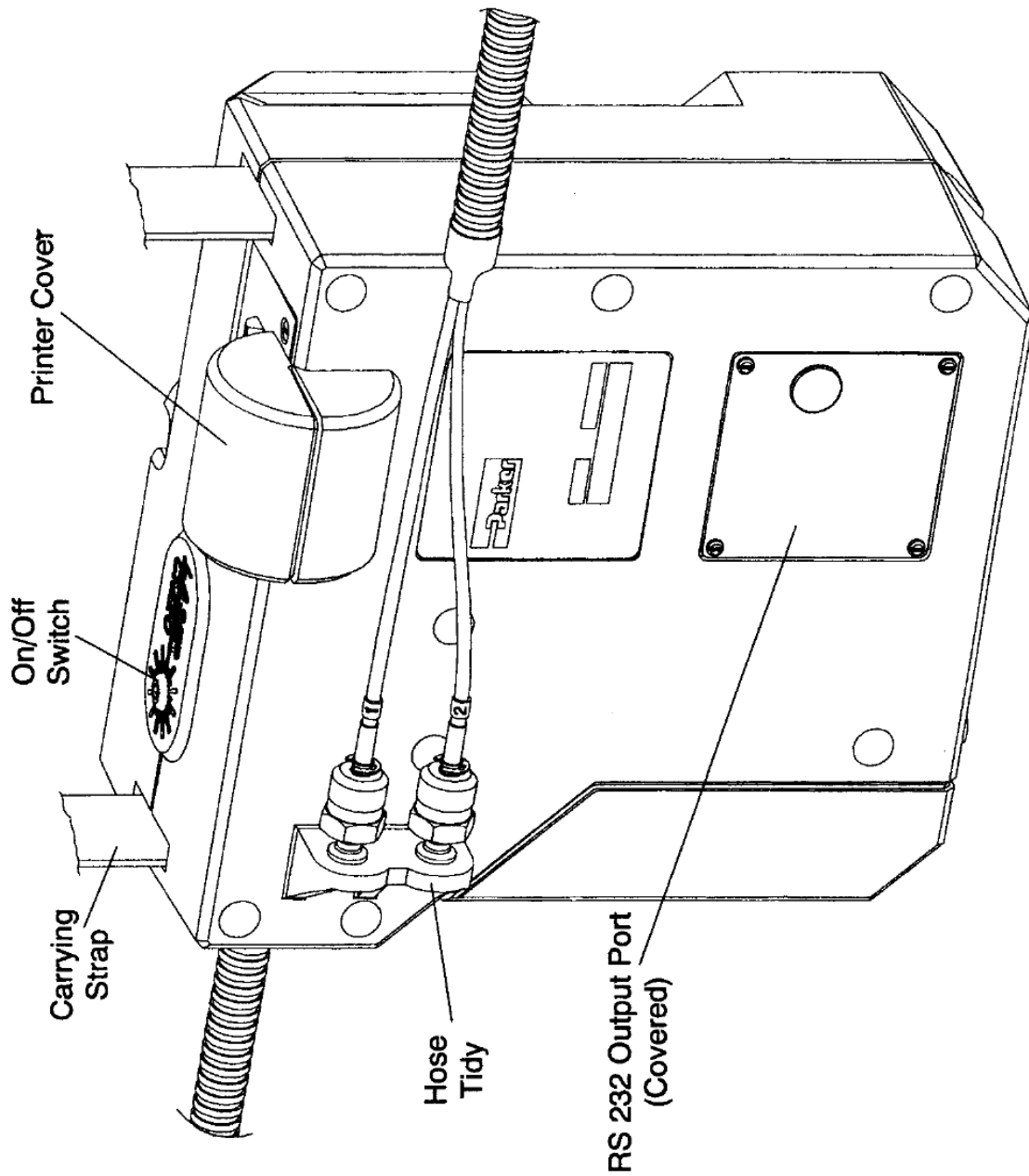

Hand-held Readout

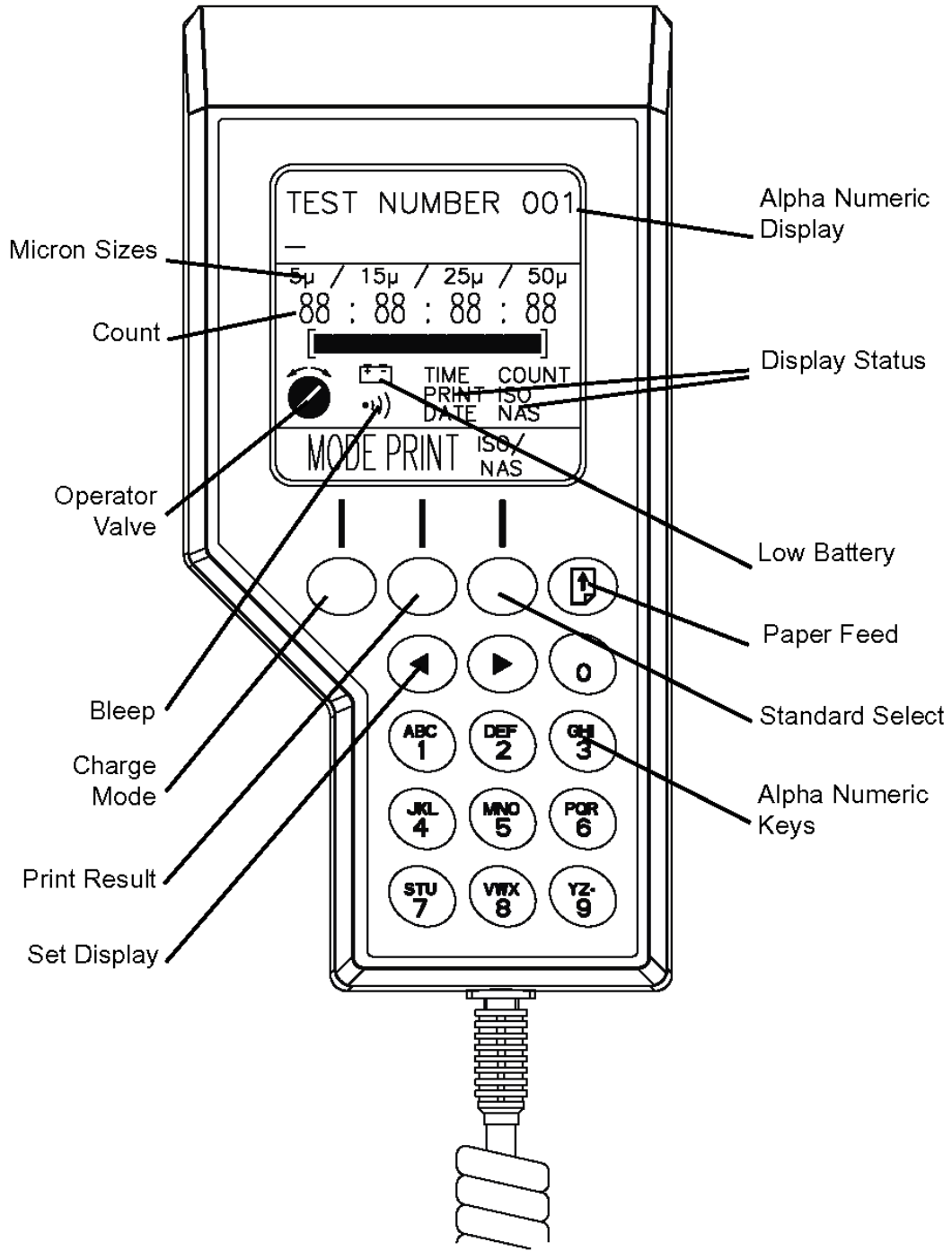

Battery Insertion**6x1.5 volt ALKALINE batteries are required.**

Laser CM20 can also be powered from a regulated 12Vdc supply (see specifications page 45) or the re-chargeable battery pack.

Step

- 1 Remove battery compartment

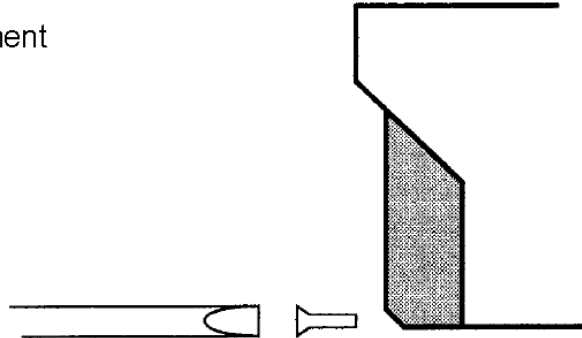

- 2 Insert batteries in the sequence shown

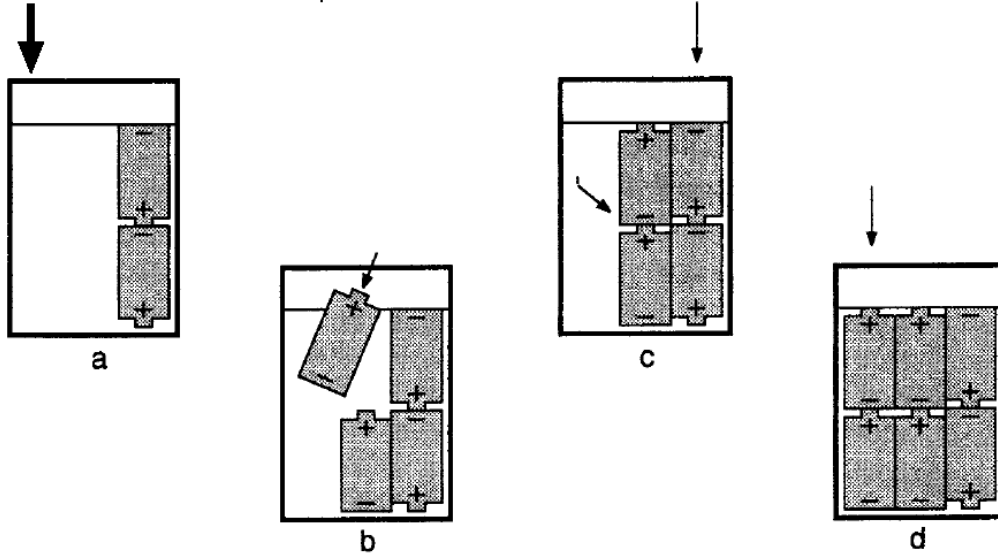

- 3 Replace battery compartment

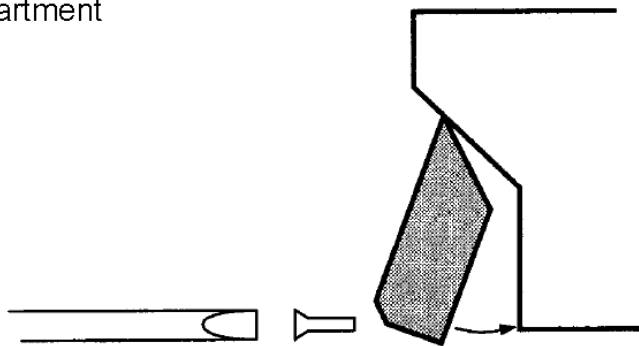

To set Laser CM20 to record time and date of tests.

PRESS

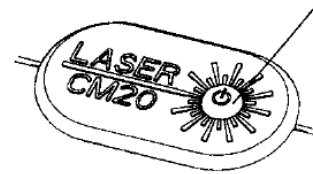

Step

- 1 Switch Laser CM20 on.
- 2 Remove handset and check display is working (see page 6). Total display will remain on for 4 seconds.

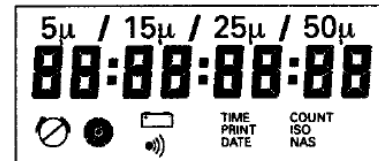

MODE

- 3 Press and hold  for 5 seconds.

Use  to move cursor under Y if 'Memory Reset' is required.

Use  to move cursor under N if 'Time and Date' reset is required.

MODE

Press  button.

- 4 Time mode displayed.
- 5 Enter correct time using numeric key pad.

Press. 

- 6 Press. 

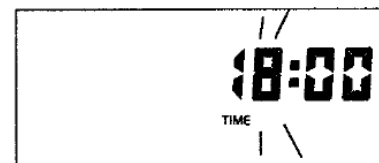
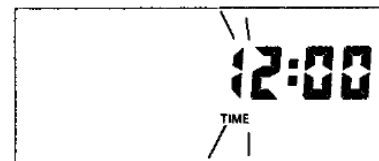

7 Press. **3**

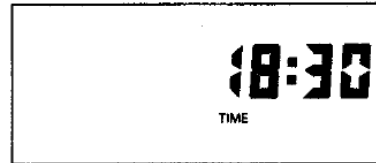

8 Press. **0**

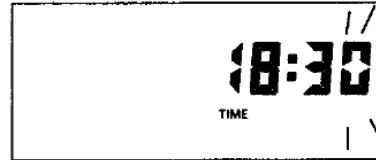

9 When correct time is displayed press. **MODE**



To set date.

Step

- 1 Having confirmed time by pressing you are ready to set date.

MODE

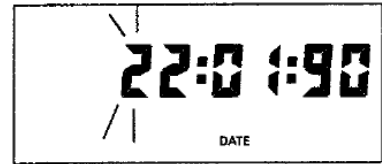

- 2 Enter correct date using numeric keypad

1

Press.



5

- 3 Press.

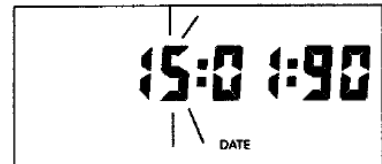

0

- 4 Press.

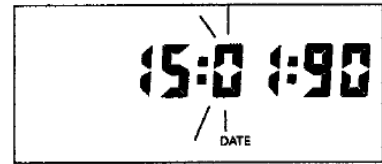

4

- 5 Press.

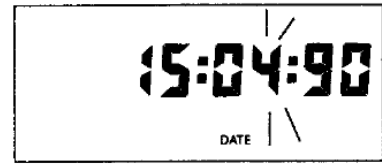

9

- 6 Press.



1

- 7 Press.



MODE



- 8 When correct date is displayed press.

Installing paper and ribbon into the printer.

Step

- 1 Remove cover and reel axle.

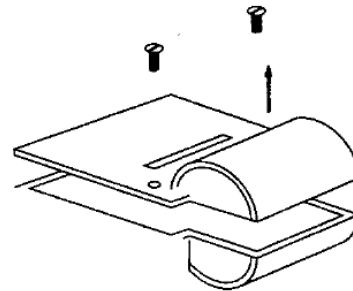

- 2 Place ribbon cassette in printer (follow numbered sequence)

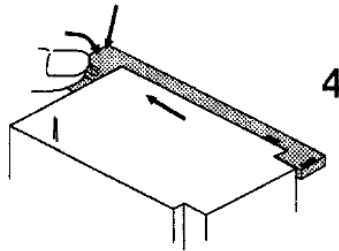
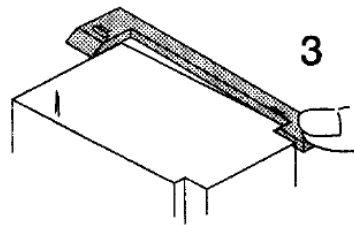
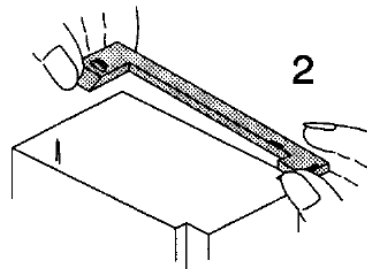
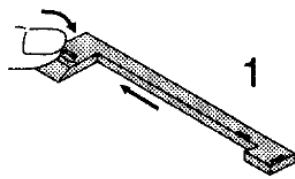

- 3 Feed paper under printer roller.

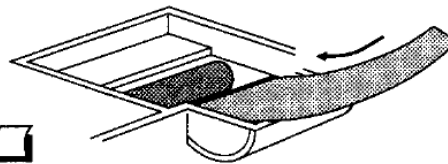

- 4 Press paper feed button on hand held unit.



- 5 Place paper in paperwell.

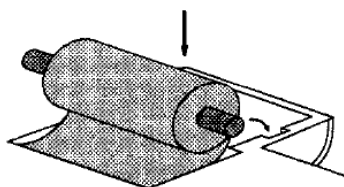

- 6 Feed paper through cover and secure cover.

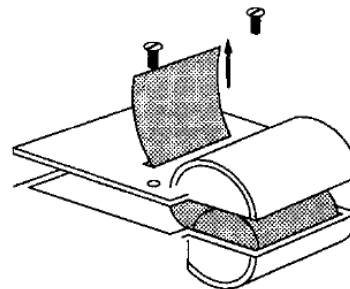

The Laser CM20 is now ready to check the cleanliness level of your system. Readings can be taken at full working pressure 420 bar (max.) In conjunction with System 20 Sensors.

Note: The Laser CM20 is supplied filled with hydraulic oil and may need to be flushed prior to use.

Step

- 1 Disconnect hydraulic hoses from the 'hose tidy'.

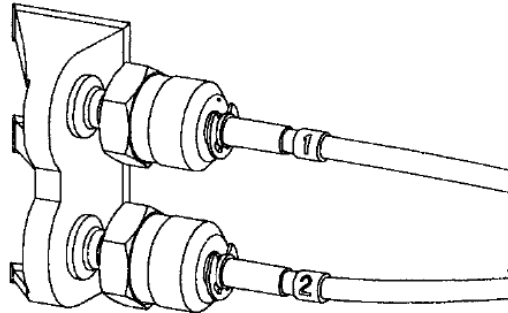

- 2 The Laser CM20 is designed for use in connection with System 20 size 0, 1 and 2 Industrial Sensors or the Single Point Sampler.

'X' DIA



Note: 'Aggressive Fluids' monitor must be connected to a special System 20 Sensor or Single Point Sampler.

Industrial

SIZE	'X'
0	30.0
1	41.0
2	66.7

- 3 Ensure Sensor is installed with arrow in direction of flow
Working viscosity 2-100 cSt.

Ensure minimum working pressure of 2 Bar

Ensure adequate oil flow through Sensor

Size 0 – 12 litres per minute

Size 1 – 40 litres per minute

Size 2 – 160 litres per minute

Disconnect protection caps 1 and 2 only (red and yellow)

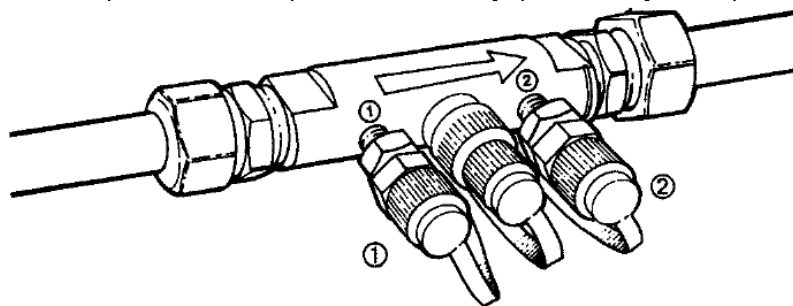

- 4 Connect red hose **1** loosely to Sensor inlet.

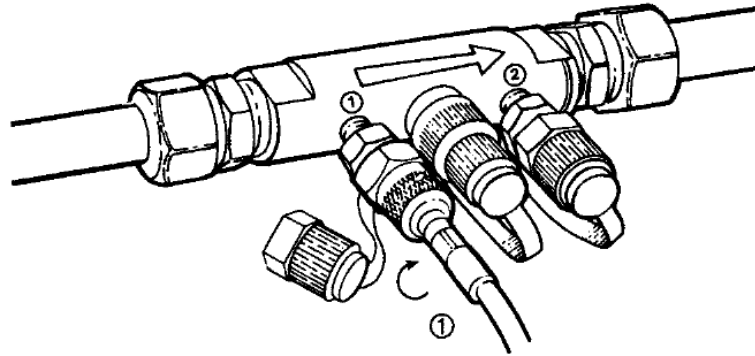

- 5 Connect yellow hose **2** loosely to Sensor outlet.

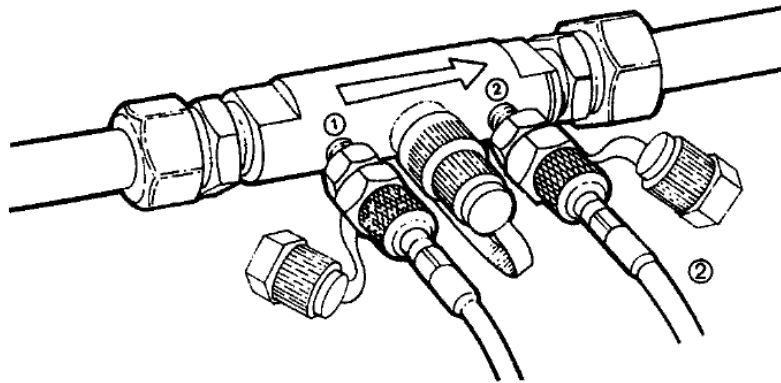

- 6 Simultaneously tighten the couplings finger tight.

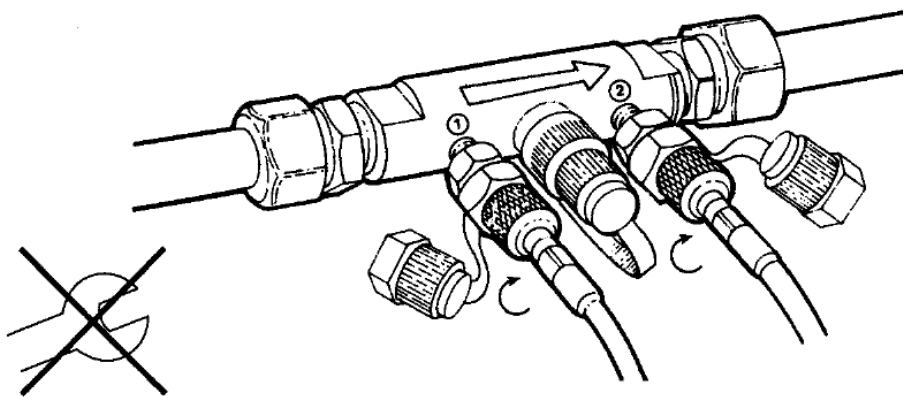

The Laser CM20 is now connected to the fluid to be checked.

We recommend Laser CM20 is connected to operating system sensor for 5 minutes to allow fluid condition to stabilise before commencing test.

It is also recommended that an independent flow check be carried out if there is high viscosity oil and low flow through System 20 sensor, or the unit is being operated without the trace heating option in cold ambient temperatures.

Independent Flow Test

1 Switch Laser CM20 on.

2 Press  for 5 seconds.

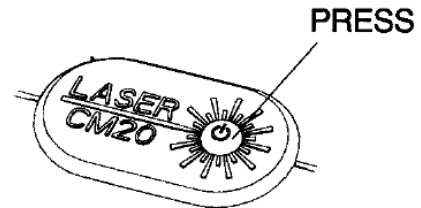

3 Flow test will commence, the display will show.

MANUAL FLOW TEST
IN PROGRESS

4 After 30 seconds the printer will print out the results of the flowtest.

5 A ΔT (Temp) of $\leq 03.60^{\circ}\text{C}$ or less is required for a successful test to be achieved.

6 If the ΔT value is $> 03.60^{\circ}\text{C}$ then the flow rate through the System 20 Sensor should be increased or the system oil temperature raised.

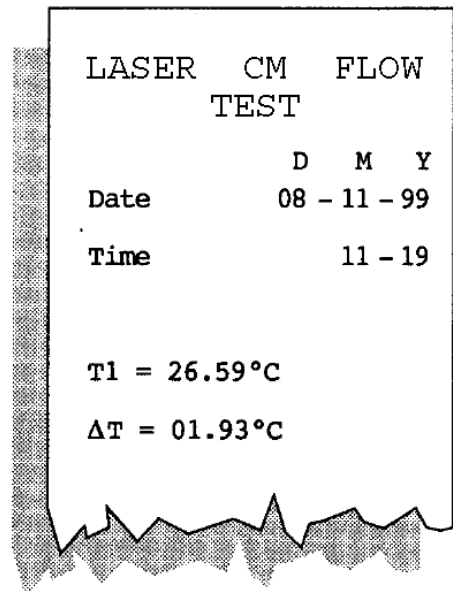
A printed receipt with a jagged bottom edge. The text on the receipt is as follows:

LASER CM FLOW
TEST

Date D M Y
08 - 11 - 99

Time 11 - 19

T1 = 26.59°C

ΔT = 01.93°C

Step

- 1 Select ISO or NAS standard. This determines the format of test data stored. **ISO/NAS**



- 2 Observe position of operation control valve system

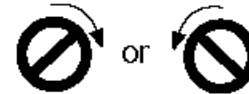

- 3 Turn valve 90° in indicated direction. Valve position can be checked from the top of the Monitor....



.... or from the front of the Monitor.

Important:

Only turn the valve when starting a test and only when the valve turn symbol

 is shown on the display.

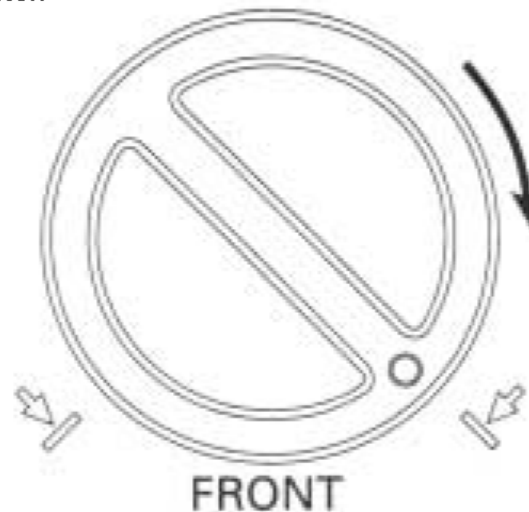

Testing will commence immediately

The test will take approximately 2 minutes. The duration bar will run across the screen for the duration of the test in 12 segments.

During each test, the appropriate test number will appear on the display. Example indicates test number 001 in progress.

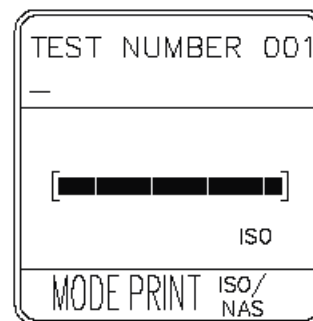

ISO Mode

During all tests a 2 μ , 5 μ and 15 μ interim count will be displayed

Step

1 When the test is complete, the ISO Code will automatically be displayed.



2 **Particle count**
To obtain a count for the 2 μ particles press the **MODE** button.



All particle counts are representative of 100 ml samples.

3 A count for 2 μ will be displayed.



4 Press  for the 5 μ count.



5 Press  again to obtain the 15 μ count.



6 Press  again to obtain the 25 μ count.

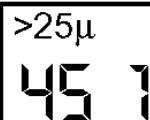

Step

7 Press  for the 50 μ count.

>50 μ

11

8 Press  once more for the 100 μ count.

>100 μ











0

9 Use  to return to previous particle count screen.

NAS Mode

When the test is complete the NAS Code will be displayed automatically.

Step

- | | | |
|---|--|---|
| 1 | <p>Press the ISO/NAS  button to set NAS mode. NAS class code will appear on the screen.</p> | <div style="border: 1px solid black; padding: 5px; width: fit-content; margin: 0 auto;">11</div> |
| 2 | <p>Press the MODE  button to obtain the NAS count 2μ to 5μ.</p> | <div style="border: 1px solid black; padding: 5px; width: fit-content; margin: 0 auto;">2μ-5μ
2774621</div> |
| 3 | <p>Press the   button to obtain the NAS count 5μ to 15μ.</p> | <div style="border: 1px solid black; padding: 5px; width: fit-content; margin: 0 auto;">5μ - 15μ
36 45 34</div> |
| 4 | <p>Press   again for the NAS count 15μ to 25μ.</p> | <div style="border: 1px solid black; padding: 5px; width: fit-content; margin: 0 auto;">15μ - 25μ
66 75</div> |
| 5 | <p>Press   again to obtain the 25μ to 50μ count.</p> | <div style="border: 1px solid black; padding: 5px; width: fit-content; margin: 0 auto;">25μ - 50μ
74 63</div> |
| 6 | <p>Press   again for the 50μ to 100μ count.</p> | <div style="border: 1px solid black; padding: 5px; width: fit-content; margin: 0 auto;">50μ-100μ
11</div> |

Step

7

Press



once more for
the 100 μ count.



Press



to return to previous particle count screen.

To enter 32 character serial identification or Test Data against test number:

Step

- 1 Press **MODE**  three times from idle to step through ISO/NAS and count modes to the serial number entry mode.

PLEASE ENTER A
TEST ID CODE

The cursor will be located at the left hand side of the top display.

- 2 Each key has four characters that can be accessed by repeatedly pressing the button.

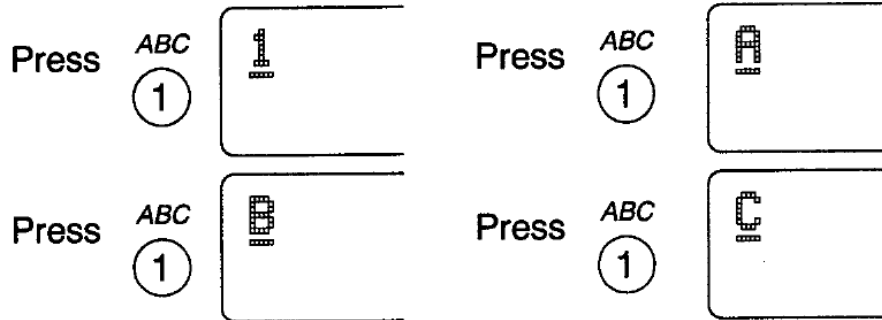

- 3 Once the required character is displayed, move on to the next button.

- 4 To input two characters from the same button:

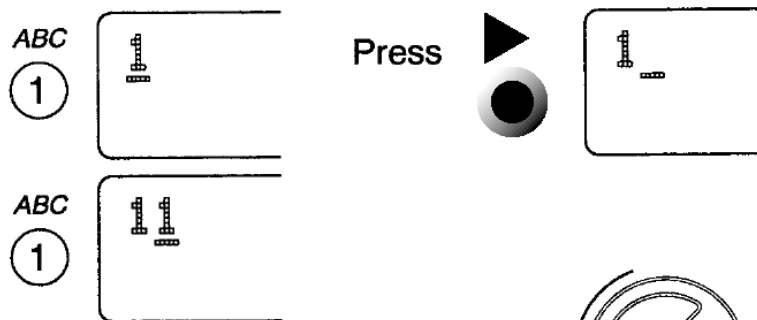

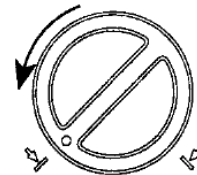

Once the identification code is displayed turn the knob



The code will be entered into the Laser CM20's memory and the test will start.

To enter 32 character serial identification or Test Data against test number:

Step

- 5 The previous identification code will be displayed automatically at the beginning of each new test.
- 6 To change the last character in the code Press  and the cursor will move to the end of the code.
- 7 If the new code to be entered is unique to the test being performed, press the first character of the new code and the display will clear. Continue as in 3.
- 8 Press  to remove previous character if a mistake has been made.
- 9 The test identification code will be printed with the test number on each test printout.

The Bar Code Wand is available as an optional extra (Standard on LCM20.2023) and allows the user to enter the 32 character serial identification or test data against the test number from a standard 39 bar code. (Consult Parker Filtration UCC).

STEP

1. Connect the bar code wand plug into socket on the side of the Laser CM20. (See Annotated Diagram - Monitor Front View).
2. Press **MODE**  three times from idle to step through ISO/NAS and count modes to the serial number entry mode.

**PLEASE ENTER A
TEST ID CODE**

3. Place the bar code wand to the left of the bar code, and with a continuous motion, swipe the wand across the bar. A successful entry will be confirmed by a single beep.

NOTE: If you wish to add data manually press MODE again or wait 50 seconds until the cursor appears in the top left hand corner

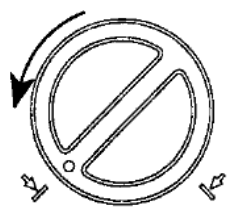
4. Once the identification code is displayed turn the knob. 

5. The test identification code will be printed with the number on each test printout and stored in the memory.



ABC 123

To print a result

To obtain a printout of the result in the ISO MODE

Step

- 1 Press the **PRINT** button once to obtain the last result.

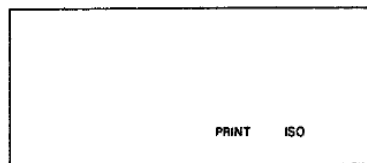

- 2 The printer will print the time, date and test number with ISO code and particle count.

Test No

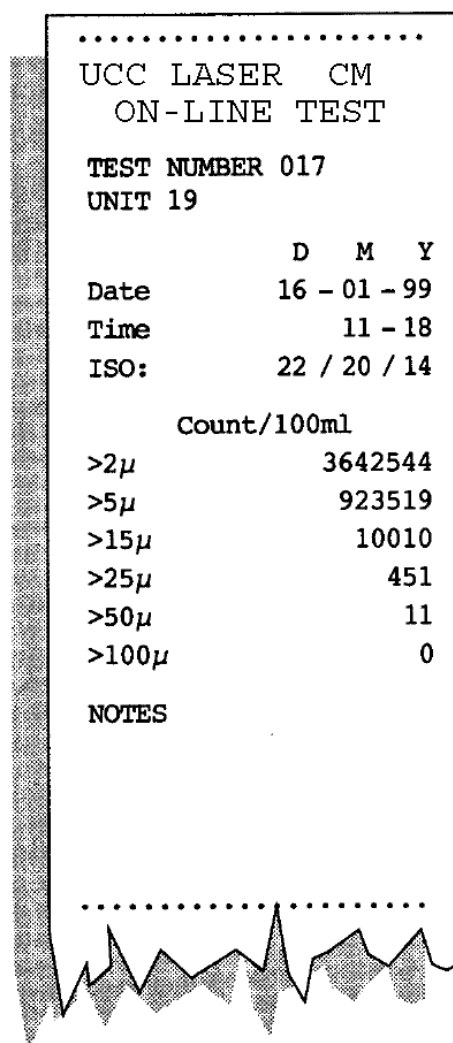

To print all tests to date
Press the print button twice

PRINT PRINT



Print stopped by pressing
a third time

PRINT



If the test count falls below ISO code 7 or above ISO code 23 then 00 or 99 respectively will be displayed under the 2µ, 5µ and 15µ symbols.

Next test

To obtain a printout of the test result in the NAS MODE

Step

- 1 Having completed the test in the NAS MODE.
Press the **PRINT** button once to obtain the last result.

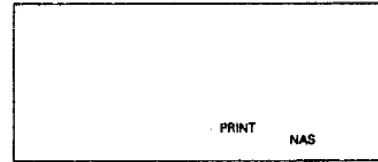

- 2 The printer will print the time, date and test number with NAS code and particle count.

Test No

.....

UCC LASER CM
ON-LINE TEST

TEST NUMBER 004
UNIT 19

	D	M	Y
Date	16	01	99
Time	09	16	
NAS CLASS			11

	Count/100ml
2/5 μ	2774621
5 μ /15 μ	364534
NAS CLASS	11
15 μ /25 μ	6615
NAS CLASS	8
25 μ /50 μ	1463
NAS CLASS	8
50/100 μ	1466
NAS CLASS	11
>100 μ	97
NAS CLASS	9

APPROVED

NOTES

.....

Next test

To print all tests to date
Press the print button twice

PRINT PRINT



Print stopped by pressing a third time

PRINT



If the test count falls below NAS class 0 or above NAS class 12 the 00 or 99 will be displayed above the NAS symbol.

Data Retrieval

To select and print a test by ID code or test number.

Press **1 ABC** for 2 seconds

DATA RETRIEVAL-
Y/N/ESC?

Press  and Select 'Y'

DATA RETRIEVAL-
Y/N/ESC?

Press **MODE**

SERIAL OR TEST
NUMBER- S/T?

Select 'S' for serial ID associated selection, or 'T' for test number associated selection.

Press  to select 'T'

SERIAL OR TEST
NUMBER- S/T?

Press **MODE**

DATA RETRIEVAL-
ENTER TEST NO ID

Enter test number required

Press **MODE** to view

RANGE IS 001-025
012

Press **PRINT** to print.

>2μ
8548760

Test 012 will now print.

To print test 012 - 001 press the print button again during the printing of the first test.
To stop press the print button one more time.

Press **MODE**

RETRIEVE MORE
RESULTS Y/N?

To view and print more results, select 'Y'. To return to the idle screen select 'N'.

Graph Printout

To select and print a graph by ID code or test number.

Press **2 DEF** for 2 seconds



GRAPH PRINTOUT-
Y/N/ESC?

Press and Select 'Y'

Press **MODE**



SERIAL OR TEST
NUMBER- S/T?

Select 'S' for serial ID selection, or 'T' for test number selection.

Press to select 'T'



SERIAL OR TEST
NUMBER- S/T?

Press **MODE**



ENTER FIRST TEST
NUMBER: _

Enter first test number required

MODE

Press



ENTER LAST TEST
NUMBER: _

Enter last test number required

MODE

Press to begin graph printout



GENERATING GRAPH
PLEASE WAIT...

- Graphs will print down the page rather than across.
- Adjacent points on the graph will be joined by a continuous line.
- Printouts for 5 and 15 micron in ISO will show separate graphs for each.
- Printouts in NAS will show one graph.
- Maximum 30 printouts in graph format.

Once completed the following message is shown:

PRINT MORE
GRAPHS Y/N

To print more graphs, select 'Y'. To return to the idle screen select 'N'.

Level Testing

To select alarm levels which control a built in relay switch module.

By choosing either the normally open or normally closed contacts, the relay module can be set to either switch on or off an external device, wired through the limit switch socket, (see annotated diagram-Front View), when the alarm levels are exceeded.

Socket Wiring Diagram

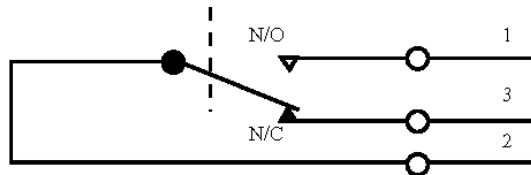

Contact Rating = 5 Amps @ 220V AC or DC

NOTE: The user is responsible for selecting the appropriately rated cable for the externally controlled device.

9 YZ

Press for 2 seconds.



Press to select 'Y'.



Enter the code level you do not wish 2u to exceed

MODE

Press and repeat this process for 5u and 15u.



Once all three levels are set, the display will show:

EDIT ALARM LEVELS
Y/N/ESC

EDIT ALARM LEVELS
Y/N/ESC

2U LIMIT:
21

LIMIT LEVELS SET

If any of the pre-set alarm levels are triggered during a manual or automatic test, an output signal will be sent and the external device will be activated.

3 GHI

Press for 2 seconds



Press to select 'Y'



MODE

Press



Press to select 'Y', the unit will run indefinitely whether the levels have been triggered or not.



MODE

Press to select 'N', the unit will run tests until the level is triggered and stop.



LEVEL TESTING
Y/N/ESC?

LEVEL TESTING
Y/N/ESC?

CONTINUOUS
Y/N?

Limit Switch Relay

To energise the level testing relay module before running a test

8VWX

Press  for 2 seconds.

Press  to select 'Y'.

MODE

Press



LIMIT SWITCH
RELAY ON Y/Q/ESC

LIMIT SWITCH
RELAY ON Y/N/ESC

Selecting "Y" will manually energise the level testing relay module.
(ie make the contact between pin 1 and 2 of the level testing relay module).

Automatic Testing

To select automatic testing function.

Press **4JKL**  for 2 seconds.

AUTOMATIC TESTING
Y/N/ESC?

Press  **MODE**  to select 'Y'.

Press **MODE** 

ENTER TEST START
TIME: 13:40

Enter the start time via the handset

Press **MODE** 

Enter the interval between test start time

TEST INTERVAL
(6-999 min):_



Press **MODE** 

ENTER NUMBER OF
TESTS TO RUN:_

Enter the number of tests to be performed via the handset (range 1 to 300 tests)



Press **MODE** 

PRINT RESULTS
Y/N/?

Press  **MODE**  to select Y; if a printout of each test is required

Press **MODE** 

START TESTING
Y/N?

Press  **MODE**  to select 'Y' to start testing

START TESTING
Y/N?

Press **MODE** 

TIME NOW: 13:42
START AT: 13:45

Testing will commence when the two times become equal and will display.

TEST NUMBER 020
FLUSHING

This will be followed immediately by a test, which will display interim counts.

TEST NUMBER 020
COUNTING

Press **MODE**  to abort this cycle on the following display and the unit will return to idle.

WAITING...
MODE TO ABORT

When all tests are complete the following display is shown.

Press **MODE**  to return to the idle screen.

AUTOMATIC
TESTING COMPLETE

Calibration Requirement

When switching the unit on, it will check the date as stored in the real-time clock against the date stored as the last calibration date.

If the date is within 4 weeks of the calibration due date, then the unit shall proceed as follows:



CALIBRATION DUE
29-06-2000

(this assumes a last calibration date of 29th June 2000)

To continue with testing press **MODE**



If the unit passes the recommended calibration due date, then the unit shall proceed as follows:



CALIBRATION
OVERDUE

To continue with testing press **MODE**



When the Laser CM20 is used with Dat ∞ m, this will allow the unit to perform additional functions, such as:

- Automatic Testing
- Route Mapping



Additional Keys



The handset has two additional hot key functions

It is supplied with factory default contrast and backlight settings.
These settings are user adjustable as detailed below.

Press and hold **5 MNO**  and use  key to lighten the screen.

Press and hold **5 MNO**  and use  key to darken the screen.

Press and hold **7 STU**  and use  to switch backlight on.

Press and hold **7 STU**  and use  to switch backlight off.

NOTE:

When the CM20 is switched off the backlight function is reset.
Therefore if the backlight is still required when the CM20 is switched back on, the backlight will then need to be reactivated.
This is to preserve battery life.

Solid contaminants in fluid power systems vary in size, shape, form and quantity. The most harmful contaminants are normally between 5 micron and 15 micron. The ISO code is the preferred method of reporting quantity of contaminants.

The ISO code number corresponds to contamination levels pertaining to three sizes.

The first scale number represents the number of particles larger than 2µm per 100 millilitre of fluid, the second number for particles larger than 5µm per 100 millilitre of fluid and the third number for particles larger than 15µm per 100 millilitre of fluid.

Below is a table of actual results, obtained, of contamination within a Hydraulic Pump endurance test rig.

Particle Size	No. of Particles per 100ml of oil
2µ	7950100
5µ	280500
15µ	1500
25µ	700
50µ	150
ISO code: 23/19/11	

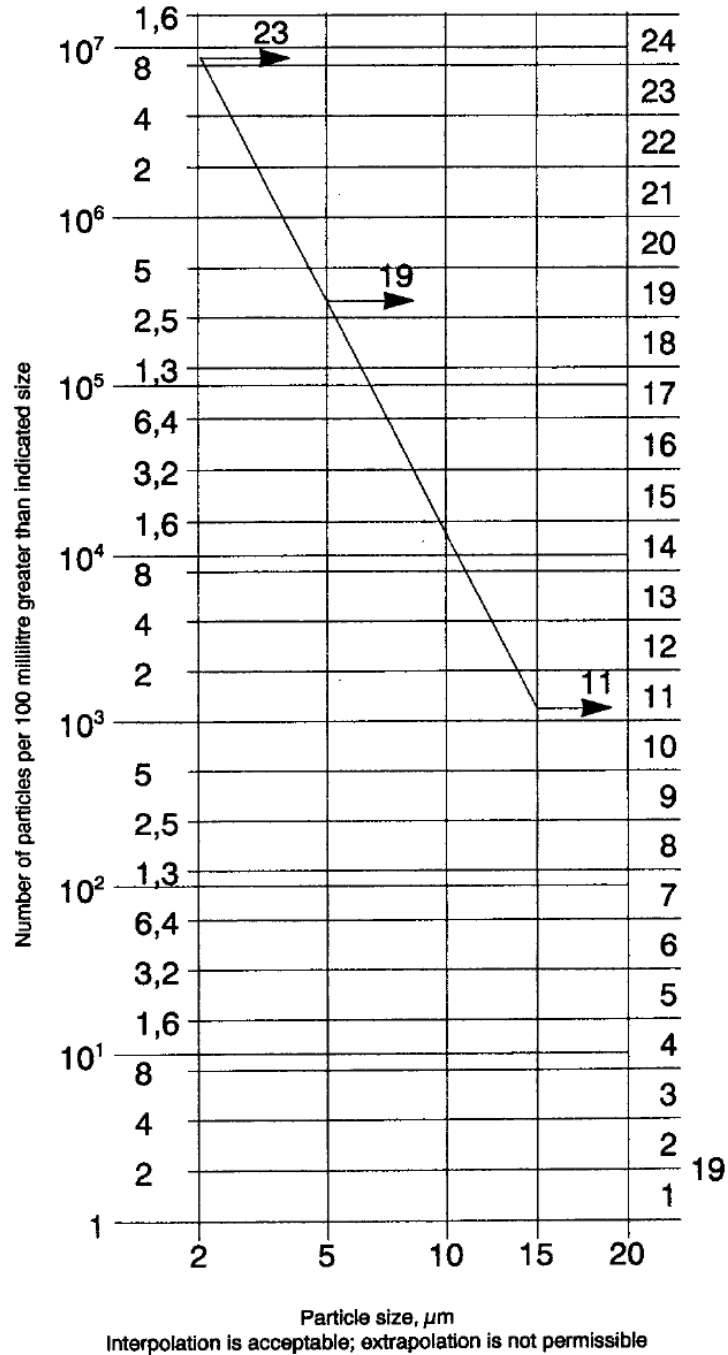

ISO Contamination Numbers

Number of particles per 100 ml		Range number
More than	Up to and including	
8 x 10 ⁶	16 x 10 ⁶	24
4 x 10 ⁶	8 x 10 ⁶	23
2 x 10 ⁶	4 x 10 ⁶	22
1 x 10 ⁶	2 x 10 ⁶	21
500 x 10 ³	1 x 10 ⁶	20
250 x 10 ³	500 x 10 ³	19
130 x 10 ³	250 x 10 ³	18
64 x 10 ³	130 x 10 ³	17
32 x 10 ³	64 x 10 ³	16
16 x 10 ³	32 x 10 ³	15
8 x 10 ³	16 x 10 ³	14
4 x 10 ³	8 x 10 ³	13
2 x 10 ³	4 x 10 ³	12
1 x 10 ³	2 x 10 ³	11
500	1 x 10 ³	10
250	500	9
130	250	8
64	130	7
32	64	6
16	32	5
8	16	4
4	8	3
2	4	2
1	2	1

For example code 20/18/13 indicates that there are between 500,000 and 1,000,000 particles larger than 2 microns and between 130,000 and 250,000 particles larger than 5 microns and between 4000 and 8000 particles larger than 15 microns.

Particle Distribution Chart to ISO4406 Including various ISO level contamination grades

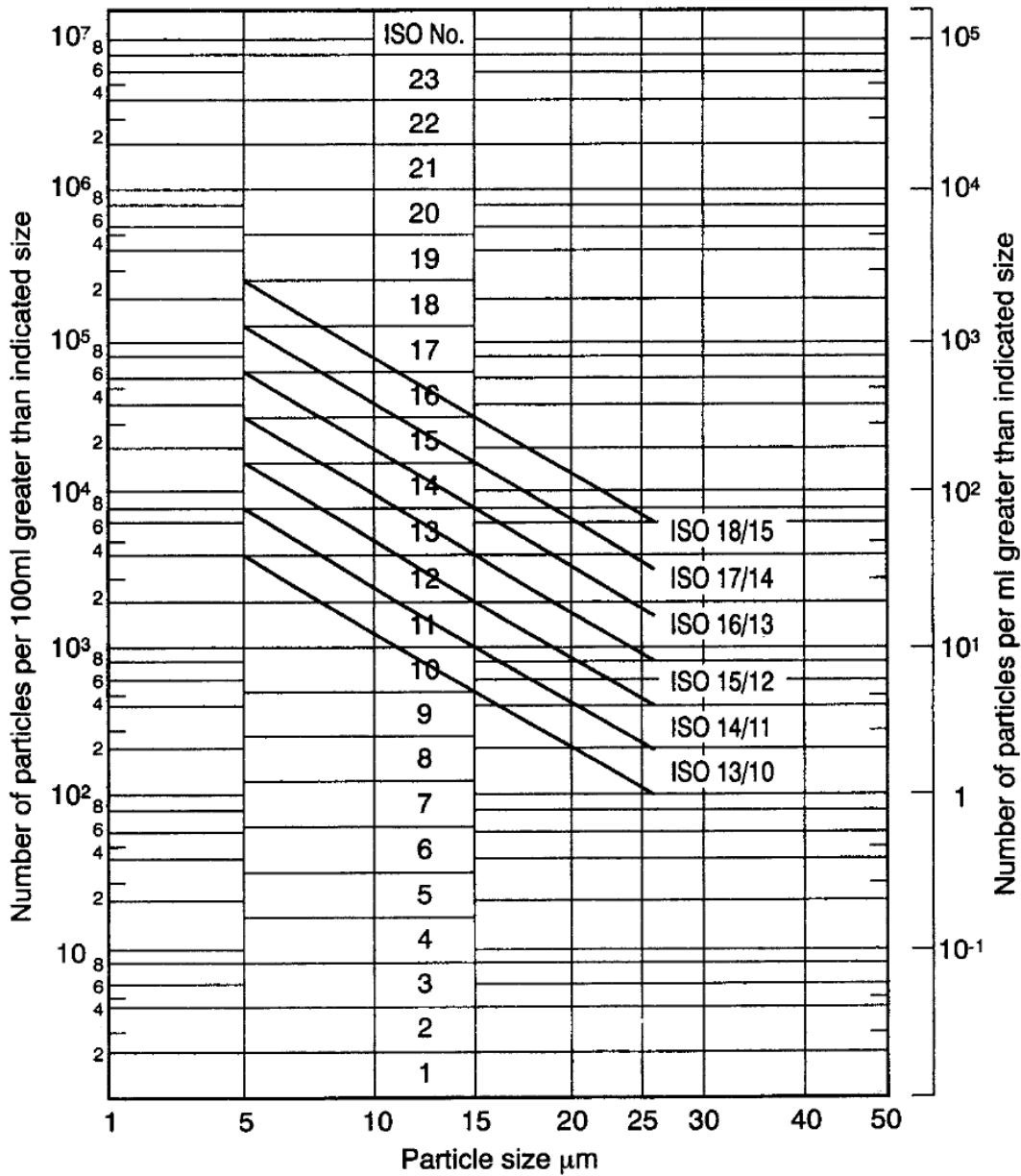

NAS 1638 Chart

NAS 1638

SIZE RANGE μm	Classes (based on maximum contamination limits, particles per 100 mL)													
	00	0	1	2	3	4	5	6	7	8	9	10	11	12
5-15	125	250	500	1000	2000	4000	8000	16,000	32,000	64,000	128,000	256,000	512,000	1,024,000
15-25	22	44	89	178	356	712	1425	2,850	5,700	11,400	22,800	45,600	91,000	182,400
25-50	4	8	16	32	63	126	253	506	1,012	2,025	4,050	8,100	16,200	32,400
50-100	1	2	3	6	11	22	45	90	180	360	720	1,440	2,880	5,760
over 100	0	0	1	1	2	4	8	16	32	64	128	256	512	1024

ISO/NAS/SAE Comparison Chart

BS 5540/4 ISO/DIS 4406 CODE	Def. Std 05/42		NAS 1638 Class	SAE 749 Class
	Table A	Table B		
11/8	-	-	2	-
12/9	-	-	3	0
13/10	-	-	4	1
14/9	-	400F	-	-
14/11	-	-	5	2
15/9	400	-	-	-
15/10	-	800F	-	-
15/12	-	-	6	3
16/10	800	-	-	-
16/11	-	1 300F	-	-
16/13	-	-	7	4
17/11	1 300	2 000F	-	-
17/14	-	-	8	5
18/12	2 000	-	-	-
18/13	-	4 400F	-	-
18/15	-	-	9	6
19/13	4 400	6 300F	-	-
19/16	-	-	10	-
20/13	6 300	-	-	-
20/17	-	-	11	-
21/14	15 000	-	-	-
21/18	-	-	12	-
22/15	21 000	-	-	-
23/17	100 000	-	-	-

The above comparisons relate to particle count data only. To conform to any particular standard, reference should be made to the recommended experimental procedure.

Suggested acceptable contamination levels for various hydraulic systems.

TARGET CONTAMINATION CLASS TO ISO 4406	SUGGESTED MAXIMUM PARTICLE LEVEL	SENSITIVITY	TYPE OF SYSTEM	TYPICAL COMPONENTS
5µm	5µm			
15µm	15µm			
13	4,000	Super critical	Silt sensitive control system with very high reliability. Laboratory or aerospace.	High performance servovalves
9	250			
15	16,000	Critical	High performance servo and high pressure long life systems, i.e. aircraft, machine tools, etc.	Industrial servovalves
11	1,000			
16	32,000	Very Important	High quality reliable systems. General machine requirements.	Piston pumps, proportional valves compensated flow controls
13	4,000			
18	130,000	Important	General machinery & mobile systems. Medium pressure, medium capacity.	Vane pumps, spool valves
14	8,000			
19	250,000	Average	Low pressure heavy industrial systems, or applications where long life is not critical.	Gear pumps, manual and poppet valves cylinders
15	16,000			
21	1,000,000	Main protection	Low pressure systems with large clearances.	Ram pumps
17	64,000			

Typical system applications and code numbers

These typical applications and ISO code numbers are taken from the UK Contamination and Control Research Programme (1980-1984).
 Ref. AHM Guide to Contamination Control in Hydraulic Power Systems – 1985

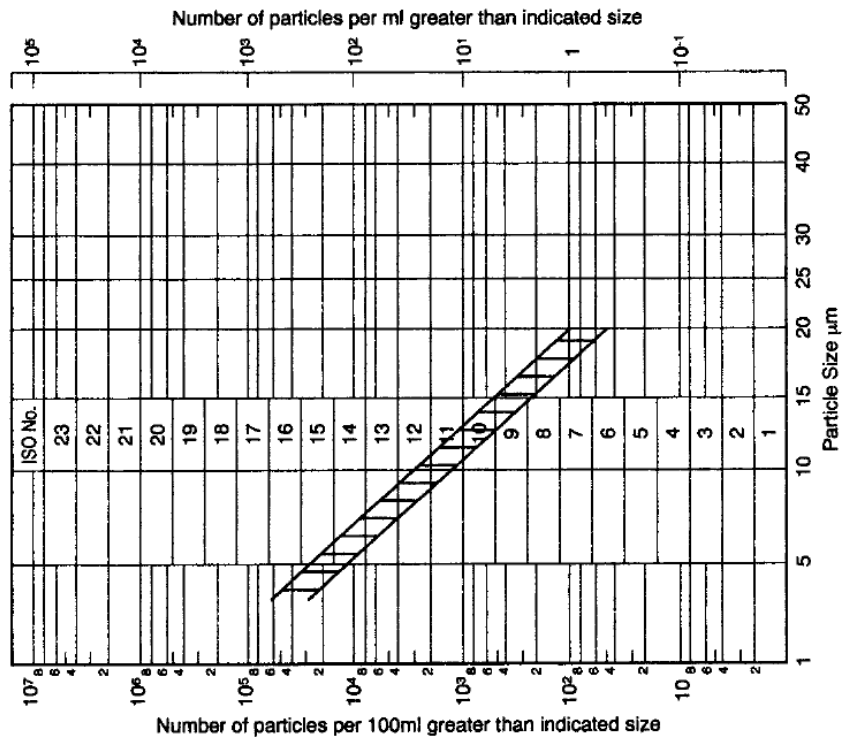

Solid Contaminant Code No 15/9
 Application: Machine Tools

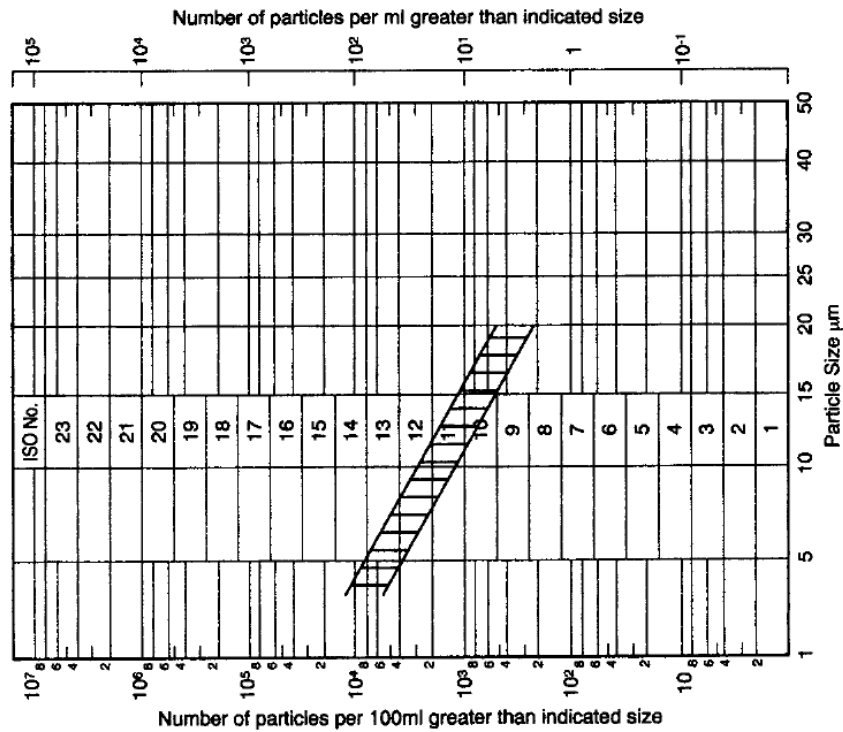

Solid Contaminant Code No 13/10
 Application: Aircraft test stands

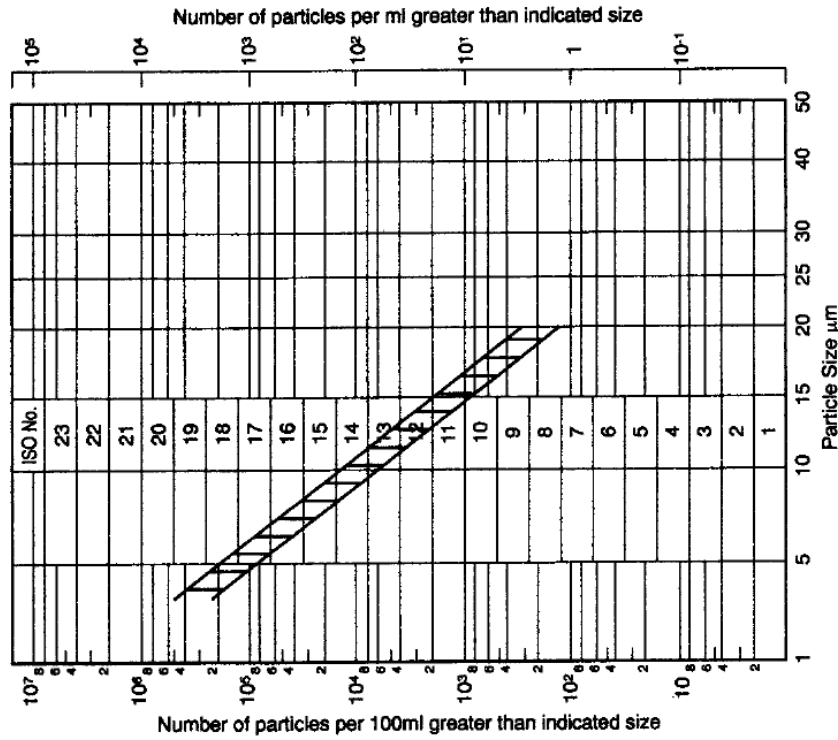

Solid Contaminant Code No 18/11
Application: Mobile Systems

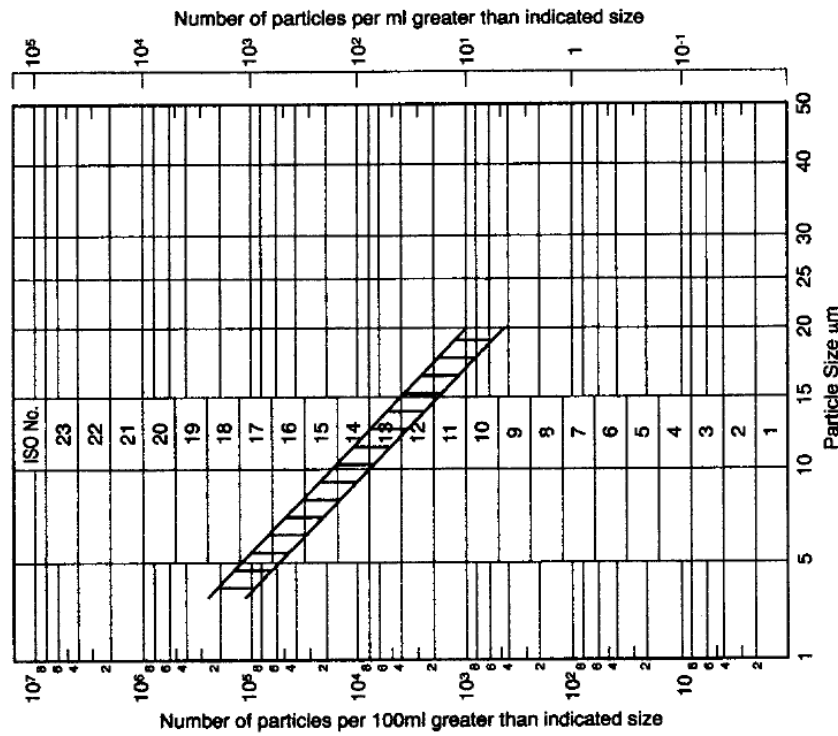

Solid Contaminant Code No 17/12
Application: Marine Installations

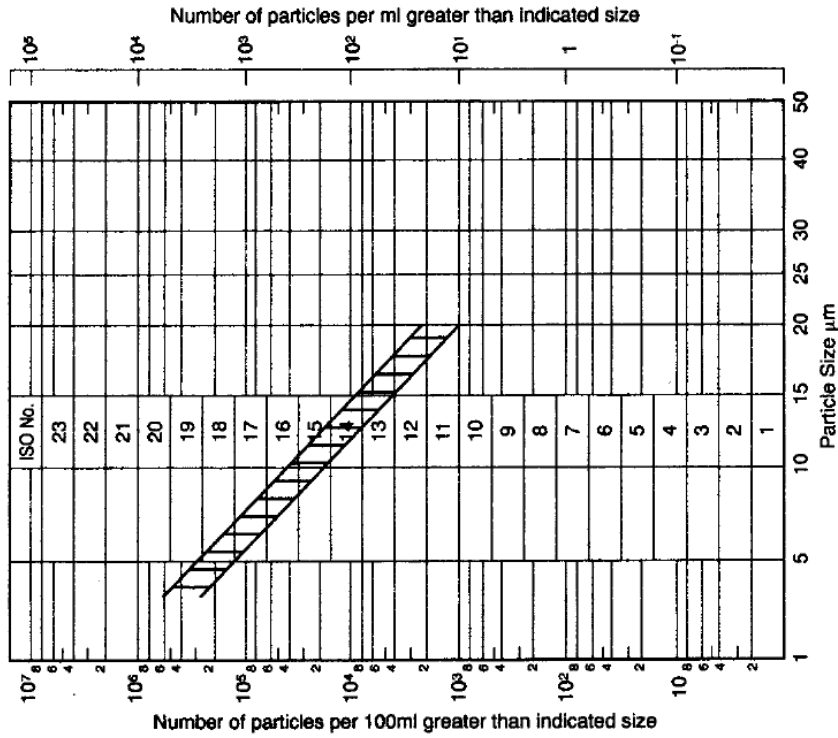

Solid Contaminant Code No 18/13
Application: Mechanical Handling

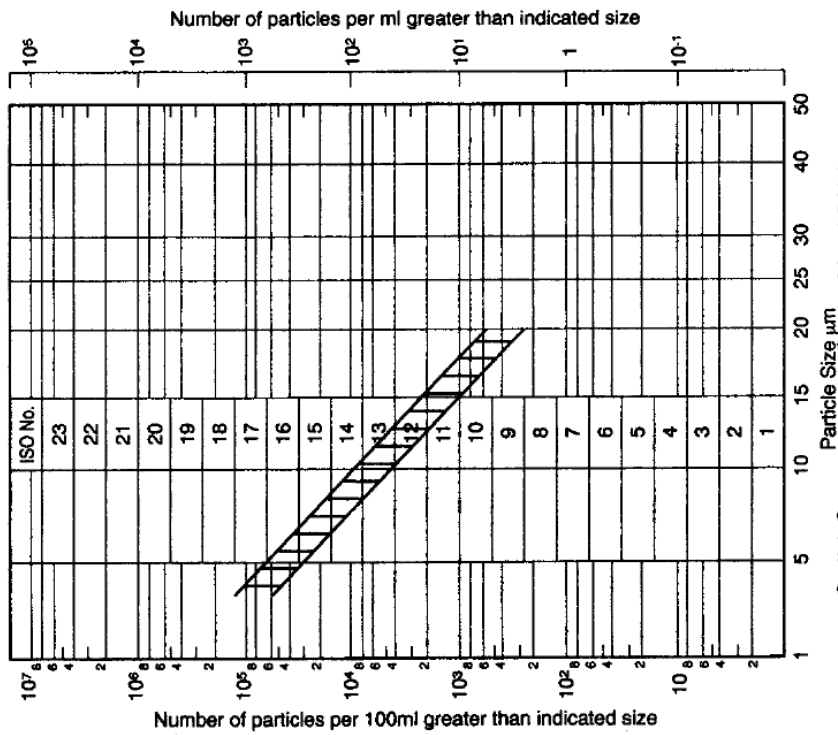

Solid Contaminant Code No 16/11
Application: Injection Moulding
Metalworking
Unused commercial grade oil

Diagrammatic representation only

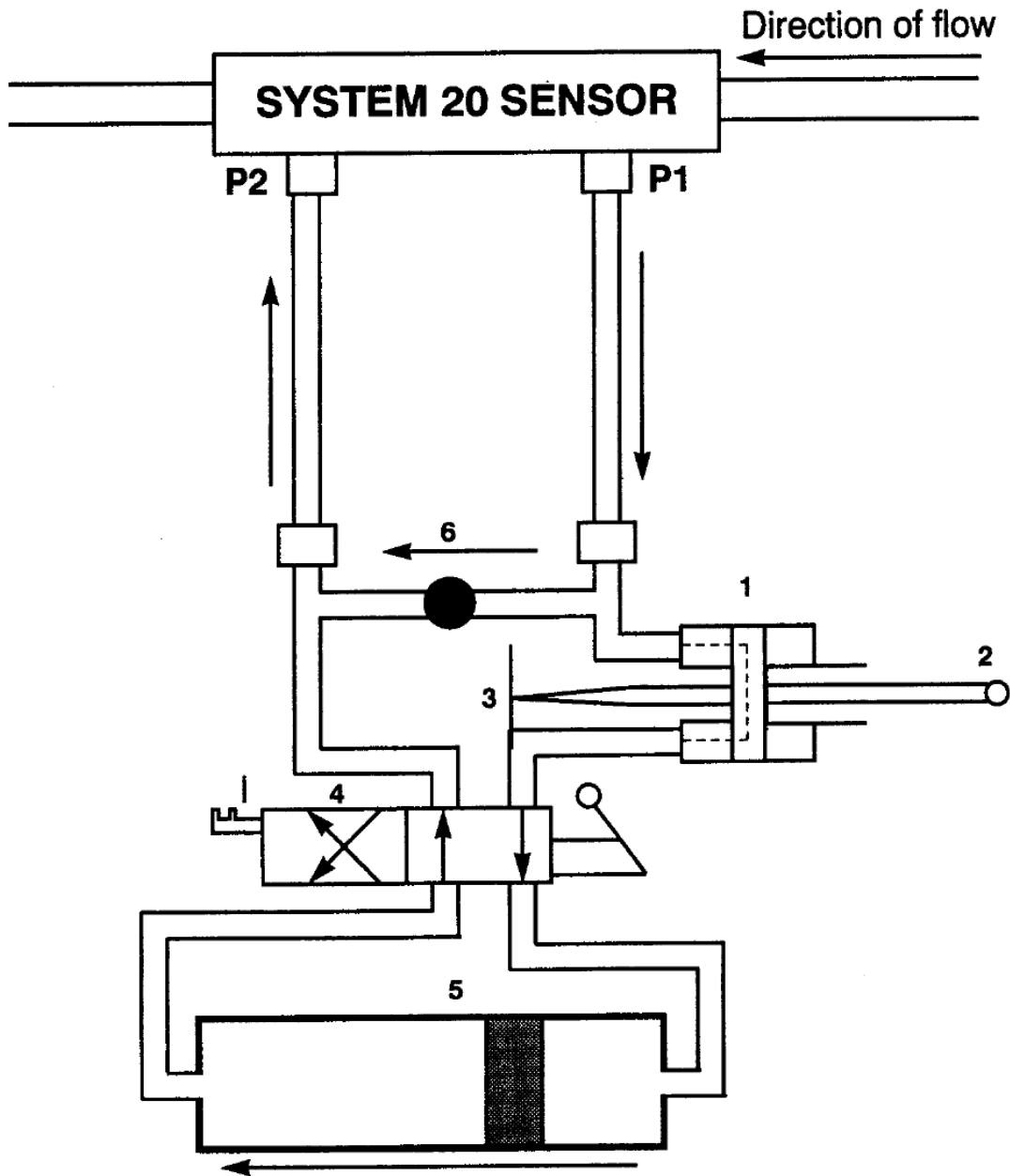

1. Monitor Block
2. Laser Diode
3. Optical Scanner
4. Changeover Valve
5. Dual Direction Syringe Pump
6. Flow Probe Device

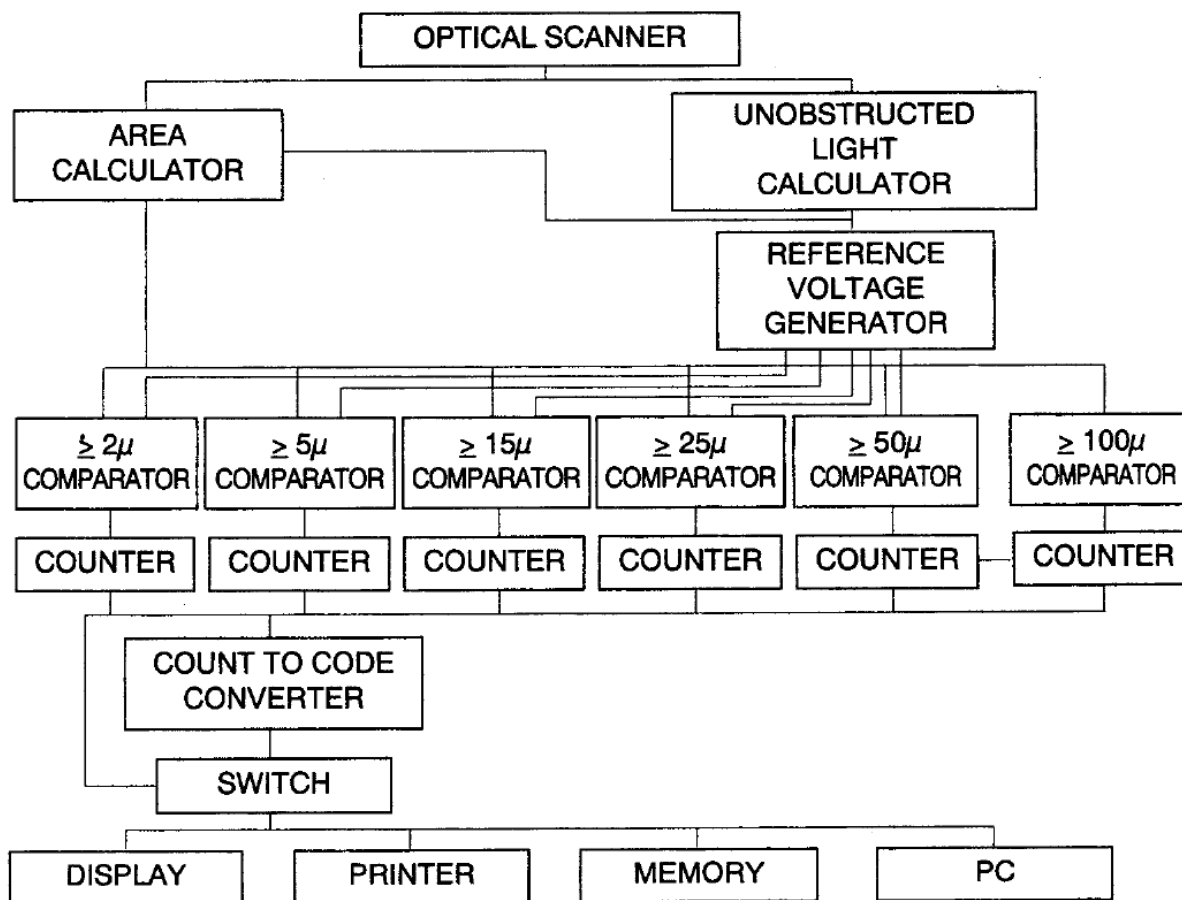

Repeatability

The Laser CM20 Instrument measures and quantifies individual particles. The sizing and counting of these particles, which is integrated within a complex electrical package, ensures a high degree of repeatability.

Calibration

Every monitor is individually calibrated using an accurately determined gravimetric level of test dust media.

Each channel within the instrument is adjusted to read the number of particles in a prescribed size range as specified in ISO procedures, thus guaranteeing calibration accuracy.

An Explanation of Laser CM20 diagnostic codes.

<p>Error 1. a. At beginning of test</p> <div style="border: 1px solid black; padding: 5px; text-align: center;"> <p>DIAG 1A. LIGHT SOURCE DEVIATION</p> </div>	<p>Oil is too dark or it is cloudy</p>	<p>Check sample of the oil visually. This can be done as follows:– Dark oils: – Wet your thumb and forefinger in the oil and press together. Release and look at your thumb. If you can see through the film of oil then it should work in Laser CM20. If you cannot then you may have problems. (This is normally engine oils or very highly contaminated oils above ISO 24)</p> <p>Emulsions – put sample in clear container and hold up to the light, this will show cloudy or clear. If cloudy check the type of oil and change until the oil is clean. Then re-try Laser CM20.</p>
<p>b. At the end of the test</p> <div style="border: 1px solid black; padding: 5px; text-align: center;"> <p>DIAG 1B. LIGHT SOURCE DEVIATION</p> </div> <p>Error 2. a. The changeover valve and syringe pump are out of phase</p> <div style="border: 1px solid black; padding: 5px; text-align: center;"> <p>DIAG 2 VALVE OPERATION ERROR</p> </div>	<p>Unstable fluid opacity may be caused by aeration water sludge or an amount of cold oil passing through Laser CM20.</p> <p>a. Control knob turned, either before monitor switched on, before valve symbol displayed on handset or during a test.</p> <p>b. Time taken to turn valve fully to next position is too long (20 seconds.)</p> <p>c. Microswitch setting fault.</p>	<p>Allow machine to work up to normal operating temperature before performing condition or monitoring. Run tests with a stable system and ensure that 2 bar minimum line pressure is available at the monitor to reduce the possibility of aeration.</p> <p>Switch off monitor, then switch on and wait for monitor to re-set its position (Diag 6 displayed). Start next test when valve symbol is displayed on handset.</p> <p>As in (a) above.</p> <p>Return to Parker Filtration UCC for repair.</p>

<p>Error 3. a. Power to monitor has been disrupted</p> <div style="border: 1px solid black; padding: 5px; text-align: center;"> <p>DIAG 3 POWER INTERRUPTION</p> </div> <p>Error 4. insufficient flow rate of oil from P1 hose into monitor block to fill syringe pump. Results are suspect and are not made available.</p> <div style="border: 1px solid black; padding: 5px; text-align: center;"> <p>DIAG 4 LOW FLOW IN BYPASS LINE</p> </div> <p>Error 5. test time too short or too long.</p> <div style="border: 1px solid black; padding: 5px; text-align: center;"> <p>DIAG 5A TEST TIME TO SHORT</p> </div> <div style="border: 1px solid black; padding: 5px; text-align: center;"> <p>DIAG 5B TEST TIME TO LONG</p> </div>	<p>a. Uncontrolled power down by removing power supply without switching monitor off.</p> <p>b. Battery power too low. Battery level warning ignored.</p> <p>c. Battery contact disconnected by excessive vibration.</p> <p>d. Power supply connected (12V DC) while unit is on.</p> <p>a. Inadequate differential pressure across P1 and P2 connections to cause sufficient bypass flow.</p> <p>b. Air lock in monitor block or high viscosity slug of oil in bypass hoses.</p> <p>a. Malfunction of Opto-Tacho control, causing flow to stop before particle counting phase completed. Results are suspect and are not made available. Pump drive slipping or failed.</p> <p>b. DP too high due to lack of control of flow through Laser CM20.</p>	<p>Wait for monitor to reset itself.</p> <p>Replace batteries with 6 x 1.5V Alkaline D Cells (or re-chargepack if rechargeable pack is fitted.)</p> <p>Relocate monitor on a sound surface (May also be hung from a carrying strap).</p> <p>Leave unit to re-set itself.</p> <p>i) Select smaller sized sensor</p> <p>ii) Reduce viscosity of system oil by increasing test temperature where possible.</p> <p>iii) Use Single Point sampler connected to P1 (see UCC catalogue for details). Purge the system pressure with P2 hose disconnected from system.</p> <p>Care should be taken to allow oil discharge safely and should only be performed by a competent operator. Re-test and if fault repeats, return monitor to Parker Filtration UCC for repair.</p> <p>Use SPS or sensor to control flow through Laser CM20</p>
--	--	---

<p>Error 6. Unit trying to re-set from last error.</p> <div style="border: 1px solid black; padding: 5px; text-align: center;"> <p>DIAG 6 LCM IN RESET MODE</p> </div>	<p>Displayed after switching on, while monitor is re-setting itself from previous error condition.</p>	<p>Leave it alone until it has re-set if it does not re-set, i.e. it switches itself off contact Parker Filtration UCC.</p>
<p>Error 7 and above.</p> <div style="border: 1px solid black; padding: 5px; text-align: center;"> <p>DIAG 7 REFER TO CM20 SUPPLIER</p> </div> <div style="border: 1px solid black; padding: 5px; text-align: center;"> <p>DIAG 8 REFER TO CM20 SUPPLIER</p> </div> <div style="border: 1px solid black; padding: 5px; text-align: center;"> <p>DIAG 9 REFER TO CM20 SUPPLIER</p> </div>	<p>All faults which can only be rectified by Parker Filtration UCC and are normally software diagnostic</p>	<p>Remove Laser CM20 from system connectors. Allow to cool down. If unit does not re-set, contact Parker Filtration UCC.</p>
<div style="border: 1px solid black; padding: 5px; text-align: center;"> <p>DIAG 10 LASER TEMP TOO HIGH</p> </div>	<p>Displayed if monitor block has reached temp. above 60°C</p>	<p>Remove Laser CM20 from system connectors. Allow to cool down. If unit does not re-set, contact Parker Filtration UCC.</p>

LOW BATTERY

Replace batteries see section (4)
The Laser CM20 will not complete a measurement if the power is insufficient.

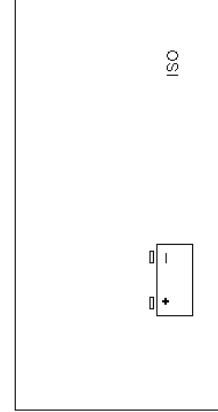

Peripherals and Serial interface.

Back Panel

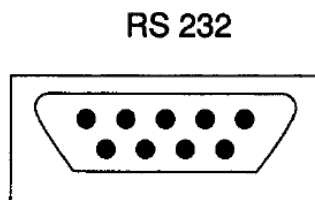
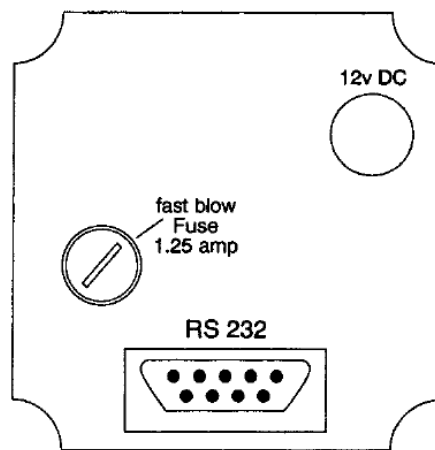

9 way connector to RS 232 output to down load all test data, stored in the instrument. (See DAT μ M SOFTWARE Package for Data Management information)

Construction: Case-Lexan structural foam and ABS. Hand-held display – ABS. Key pad fluorosilicone rubber.

Mechanical Components: Brass, plated steel, stainless steel and aluminium.

Seals: Viton.

Hoses: Nylon (Kevlar braided microbore). St. steel armoured ends.

Hose length: Fluid connection hose 1.2 metres (1 metre extensions can be used). Hand-held display cable length 1.0 metres.

Flow Rate: Up to 400 l/min (System 20 Sensors). Higher with Single Point Sampler – Consult Parker Filtration UCC.

Max. Working Pressure: Up to 420 bar (System 20 Sensors).

Fluid Compatibility: Mineral oil and petroleum based fluids. For other fluids consult Parker Filtration UCC.

Power: Battery 6x1.5D cells Transformer supply voltage 9-12Vdc. Current 1.5 amp. Jack plug connection positive centre.



(Plug supplied)

Fuse: 1.25 amp fast blow fuse included for overload protection (spare supplied).

LCM20 Technology: Unique optical scanning system.

Size, Measurement and Ranges: 2+, 5+, 15+, 25+, 50+ and 100+ micron.

Analysis Range: ISO 7 to 22 inclusive. (NAS 0-12 inclusive).

Calibration: Each unit is individually tested and calibrated in accordance with ISO procedures.

Repeatability/Accuracy: Better than 5% (typical).

Viscosity Range: 2-100 centistokes (500cSt with SPS).

Max. Operating Temp: +5°C to +80°C.

Environmental Temp: +5°C to +40°C.

Test Completion Time: 2 minutes.

Computer Interface: RS232 @ 9600 baud rate.

Laser CM20 Weight: 8 kg.

Monitor Carrying Case: Astra Board case.

Carrying Case Weight: 5 kg.

Commissioning Kit: Includes. 6-off batteries, 1-off, print rolls (shrink wrapped), 2-off printer ribbons.

Also included:

DATUM plus cable

Weather protector cover

12Vdc power supply

Rechargeable battery pack.

Installation Details

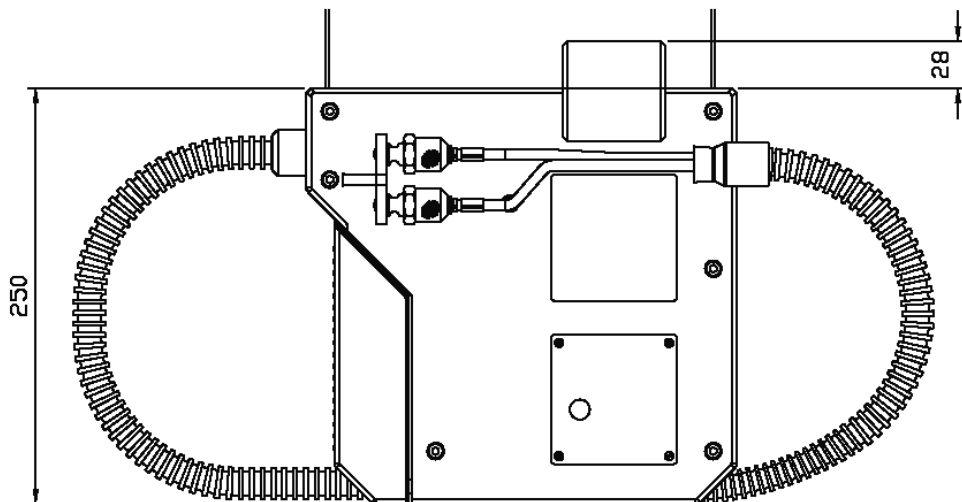
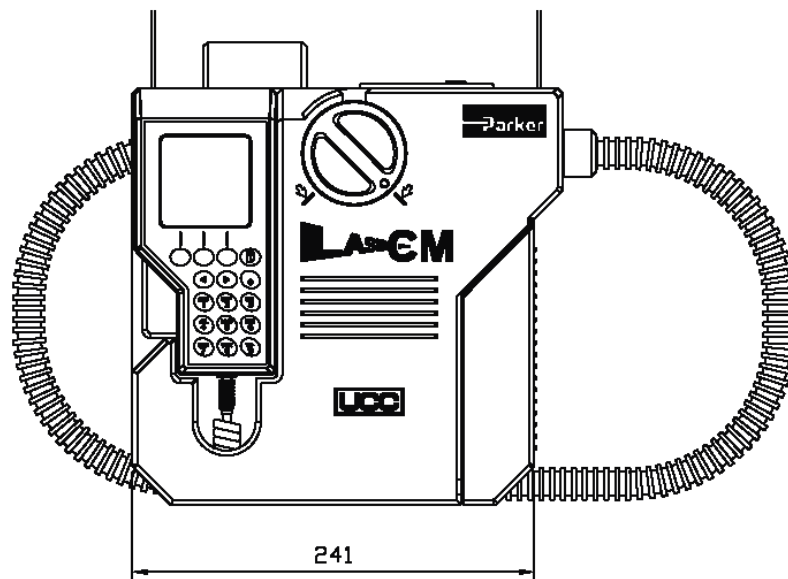
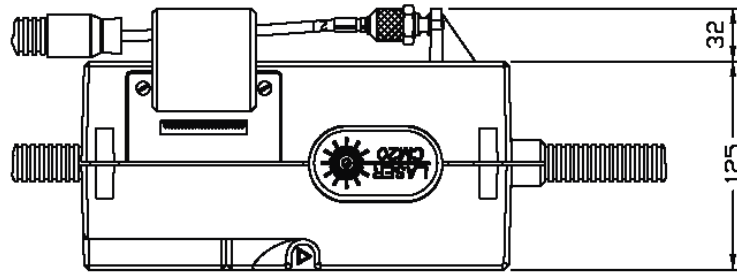

Part No.	Description	Qty.
LCM20.2021/2023	LCM 6 Channel (including carrying case and kit). ACFTD Calibrated	
LCM20.2022/2024	LCM 6 Channel MTD Calibrated	
P.843693.AB	Spare Astra Board case.	
B.84.702	Printer paper (to suit paper reel 44mm wide x 45mm diameter). Five rolls.	
P.843702	Printer ribbon.	
B.84.779	Datum System Monitoring Data Download.	
B.84.708	Cable Link Package.	
SPS. 2021	Single Point Sampler.	
B.84.609	Rechargeable battery pack.	
P.849613	Weather Protector Cover	
B.84.729	Power Supply	

Industrial Sensors - sizes 0,1 and 2

Part No.	Size	Flow Range	Thread	Qty.
STI.0144.100	0	6-25 l/min	G ³ / ₈	
STI.0344.100	0	0.5-7 US GPM	³ / ₄ UNF	
STI.1144.100	1	20-100 l/min	G ³ / ₄	
STI.1344.100	1	5-26 US GPM	SAE 1 ¹ / ₈ -12UN-2B	
STI.2144.100	2	80-380 l/min	G1 ¹ / ₄	
STI.2344.100	2	21-100 US GPM	SAE 1 ⁵ / ₈ -12UN-2B	

Always ensure:

- Sensors are installed correctly
- Sensor connectors are correctly tightened
- Adequate oil flow
- Steady state pressure conditions
- Oil viscosity is within working range
- Trend monitoring is performed under similar working conditions
- Correctly stowed hoses to avoid fluid spillage
- Sufficient paper supplies for hard copy printer
- Handle Laser CM20 with care – Instrumentation product
- Re-order spares in advance
- Calibrated within ParkerFiltration UCC recommendations

Installation Details

Battery pack removal

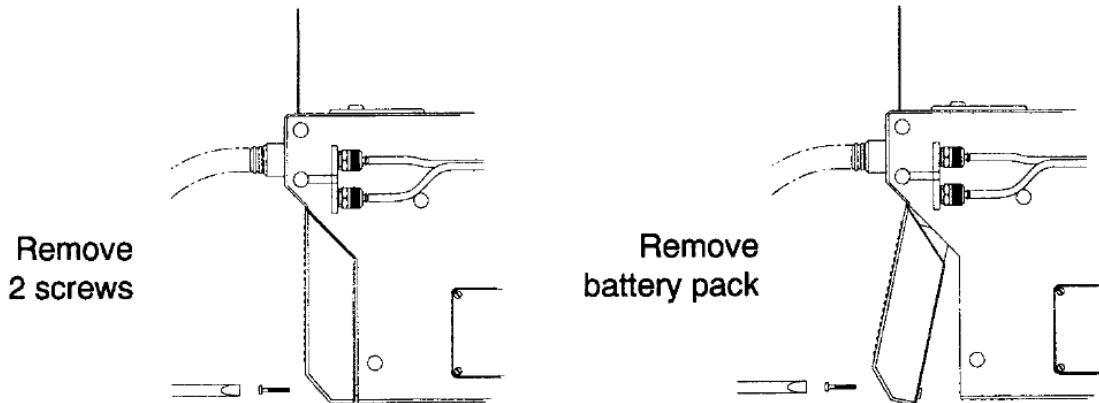

Do not short circuit positive and negative terminal plates

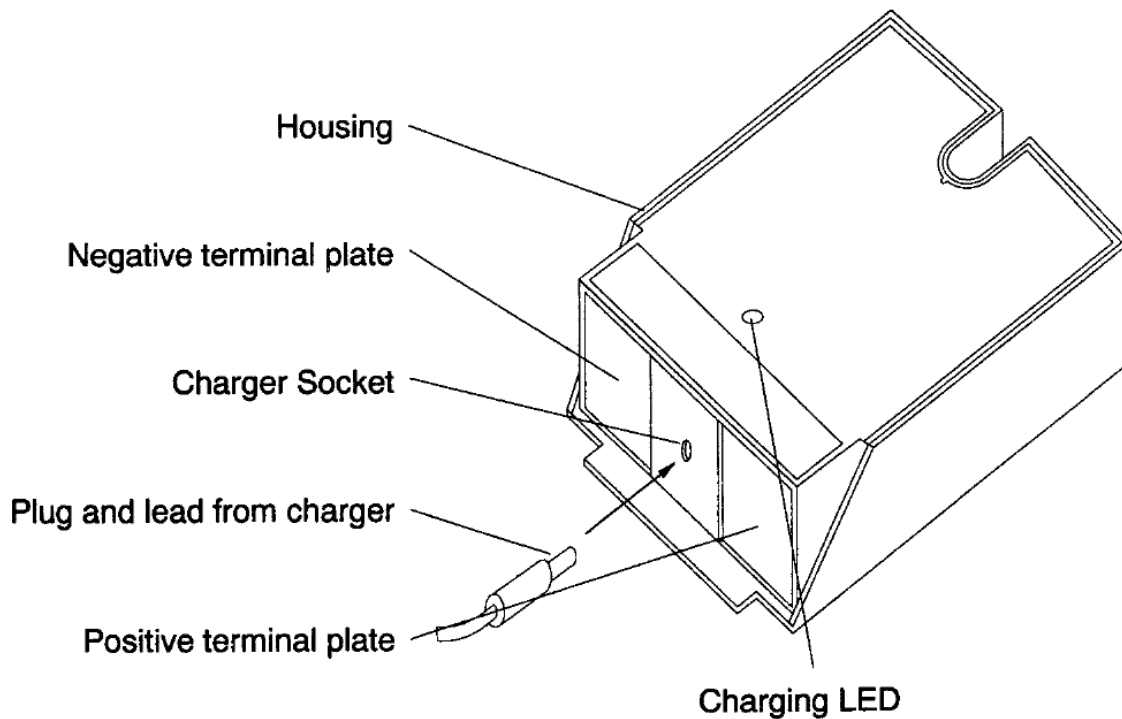

Battery pack re-charge procedure

- 1) Connect battery pack to 12Vdc supply

Ensure that the jack polarity is correct before charging



- 2) During charging the red LED will flash

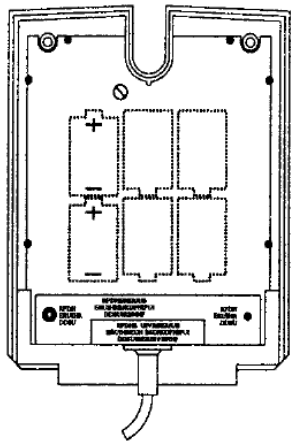

- 3) When the battery pack is fully charged the red LED will stay continuously illuminated

- 4) Disconnect the battery pack from the power supply (charger) and insert into the LASER CM20

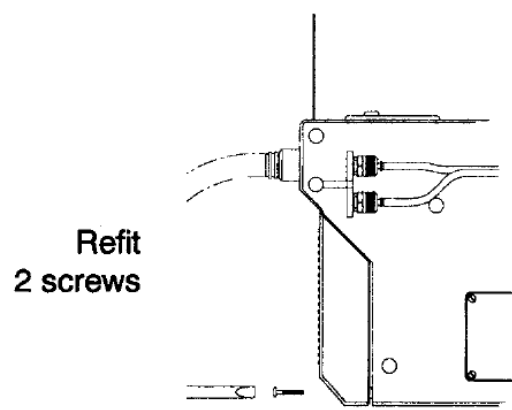
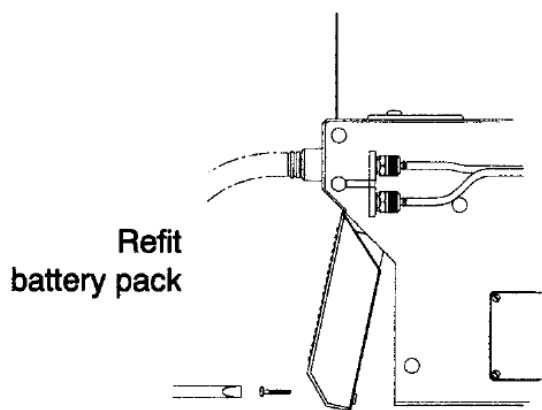

Features:

- EPDM (ETHYLENE PROPYLENE DM) seals throughout
- Totally compatible for Aggressive Phosphate Esters (e.g. SKYDROL LD4/500B)
- Red control valve knob and hand set keys for easy identification against standard Laser CM20 units
- High Technology, fused optical windows for high particle definition
- Available with complete range of sample extraction options (e.g. System 20 Sensors or Single Point Sampler)
- 5/8" BSF HSP Hose fitting
- Parylene treated for additional protection

To expand further the applications possible with Parker Filtration UCC's Laser CM20 particle counting technology, Parker Filtration UCC are now able to offer a version of Laser CM20, utilising EPDM seal technology, which is the only sealing elastomer universally accepted by the civil aviation hydraulic manufacturers. (e.g. SKYDROL PROTROLIUM)

Calibrated in accordance with ISO procedures, on a specially commissioned Skydrol calibration rig. The LCM20.2061 offers the user all the features and benefits of the already proven and world-wide accepted Laser CM20 technology.

By using LCM20.2061, civil aviation hydraulic servicing operations can now parallel the cost and time saving already demonstrated in the military aviation industries.

*Ref.; Parker Filtration UCC Technical Update UC.TU.9303.

WARNING

1. EPDM SEALED PRODUCTS MUST NEVER BE USED ON MINERAL OR SYNTHETIC BASED OILS DUE TO SEAL INCOMPATIBILITY.

2. ANY OIL SPLASHED ON PRODUCTS SHOULD BE REMOVED IMMEDIATELY TO AVOID LONG TERM DAMAGE

NOTE:

Some oils may be classified as Phosphate Esters, but may not be aggressive and not compatible with EPDM seals. If in doubt with fluid/seal compatibility, consult Parker Filtration UCC.

Part No.	Description	Qty.
LCM20.2061/2063	Laser CM20 'Aggressive Fluids' ACFTD Calibrated	
LCM20.2062/2064	Laser CM20 'Aggressive Fluids' MTD Calibrated	
P.843693.AB	Spare Astra Board case.	
B.84.702	Printer paper (to suit paper reel 44mm wide x 45mm diameter). Five rolls.	
P.843702	Printer ribbon.	
B.84.779	DATUM System Monitoring Data Download.	
B.84.708	Cable Link Package.	
SPS.2061	Single Point Sampler.	
B.84.609	Re-chargeable battery pack.	
B.84.729	Power Supply.	
P.849624	Hand Set cover.	

System 20-Sensors

Industrial Sensors - sizes 0,1 and 2

Part No.	Size	Flow Range	Thread	Qty.
STI.0148.100	0	6-25 l/min	G ³ / ₈	
STI.0348.100	0	0.5-7 US GPM	³ / ₄ UNF	
STI.1148.100	1	20-100 l/min	G ³ / ₄	
STI.1348.100	1	5-26 US GPM	SAE 1 ¹ / ₈ -12UN-2B	
STI.2148.100	2	80-380 l/min	G1 ¹ / ₄	
STI.2348.100	2	21-100 US GPM	SAE 1 ⁵ / ₈ -12UN-2B	



APPENDIX II

Calibration Certificate