

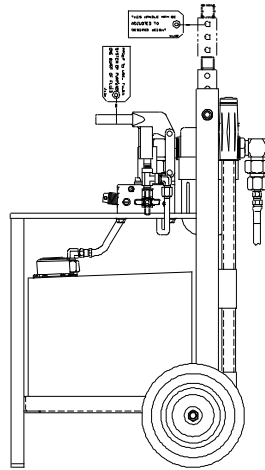

Operation & Service Manual



Models: 06-4035C Series
06-4035C0500, 06-4035C0800,
06-4035C3300, 06-4035C3600
Fluid Service Unit



11/2014 – Rev. 01

Includes Illustrated Parts List

REVISION
OR
01

DATE
08/2000
11/2014

TEXT AFFECTED
Original release
Added 06-4035C3300

TABLE OF CONTENTS

PAGE

1.0	PRODUCT INFORMATION	1
1.1	DESCRIPTION	1
1.2	MODEL & SERIAL NUMBER	1
1.3	MANUFACTURER	1
2.0	SPECIFICATIONS	1
3.0	FEATURES	1
4.0	PREPARATION FOR USE	1
5.0	TRAINING	1
5.1	TRAINING REQUIREMENTS	1
6.0	OPERATION	1
6.1	UNIT USE	1
6.2	COMPONENT TESTING	2
7.0	PROVISION OF SPARES	2
7.1	SOURCE OF SPARE PARTS	2
7.2	RECOMMENDED SPARE PARTS LISTS	2
8.0	IN SERVICE SUPPORT	2
9.0	GUARANTEES/LIMITATION OF LIABILITY	2

APPENDIX I	Hand Pump - HC-2545
APPENDIX II	Hand Pump - HC-2557
APPENDIX III	Declaration Of Conformity

This product can not be modified without the written approval of Tronair, Inc. Any modifications done without written approval voids all warranties and releases Tronair, Inc., its suppliers, distributors, employees, or financial institutions from any liability from consequences that may occur. Only Tronair OEM replacement parts shall be used.

1.0 PRODUCT INFORMATION

1.1 DESCRIPTION

The Tronair Fluid Service Unit is a compact unit designed to provide a source of clean, pressurized fluid for filling reservoirs, bleeding brakes and other maintenance functions.

1.2 MODEL & SERIAL NUMBER

Reference nameplate on unit

1.3 MANUFACTURER

TRONAIR, Inc.
1740 Eber Road
Holland, Ohio 43528-9794 USA

Telephone: (419) 866-6301 or 800-426-6301
Fax: (419) 867-0634
E-mail: sales@tronair.com
Website: www.tronair.com

2.0 SPECIFICATIONS

- Tank Capacity: 8 gallons
- Maximum Pressure: 5000 PSIG
- Fluid:
 - 06-4035C0500MIL-PFR-5606/MIL-PFR-83282
 - 06-4035C0800MIL-L-23699, MIL-PRF-87257
 - 06-4035C3300HyJet V
 - 06-4035C3600Phosphate Ester

Filtration: 2 Micron

Weight: 65 lbs

3.0 FEATURES

- 15 foot hose
- Pressure gauge
- Shut-off valve for component testing
- 5,000 PSI pump provides high pressure capability

4.0 PREPARATION FOR USE

The unit is shipped fully assembled and only the following steps are required to make the unit operational:

1. Service Reservoir: Fill reservoir with appropriate clean fluid
2. Adjust handle height to suit

Remove Air From Unit System By:

1. Close manual pump release screw located at lower right corner of pump base block
2. Open shut-off valve adjacent to pressure gauge
3. Flow fluid by actuating manual pump

5.0 TRAINING

5.1 TRAINING REQUIREMENTS

The employer of the operator is responsible for providing a training program sufficient for safe operation.

6.0 OPERATION

6.1 UNIT USE

Follow the steps below:

1. Securely attach hose to the aircraft
2. Close pump release screw
3. Open shut-off valve
4. Transfer fluid by actuating the manual pump

When service has been completed:

1. Open pump release screw to relieve pressure
2. Disconnect hose from aircraft
3. Install hose end dust plug

6.0 OPERATION (continued)

6.2 COMPONENT TESTING

A shut-off valve had been provided to assure no back flow of fluid. Therefore, shut-off valve is to be closed after the required pressure has built up in the system.

Pressure is relieved by opening this shut-off valve and the pump release screw.

7.0 PROVISION OF SPARES

7.1 SOURCE OF SPARE PARTS

Spare parts may be obtained from the manufacturer:

TRONAIR, Inc.

1740 Eber Road

Holland, Ohio 43528-9794 USA

Telephone: (419) 866-6301 or 800-426-6301

Fax: (419) 867-0634

E-mail: sales@tronair.com

Website: www.tronair.com

7.2 RECOMMENDED SPARE PARTS LISTS

Reference the following page(s) for Replacement Parts and Kits available.

8.0 IN SERVICE SUPPORT

Contact Tronair, Inc. for technical services and information. See Section 1.3 – Manufacturer.

9.0 GUARANTEES/LIMITATION OF LIABILITY

Tronair products are warranted to be free of manufacturing or material defects for a period of one year after shipment to the original customer. This is solely limited to the repair or replacement of defective components. This warranty does not cover the following items:

- a) Parts required for normal maintenance
- b) Parts covered by a component manufacturers warranty
- c) Replacement parts have a 90-day warranty from date of shipment

If you have a problem that may require service, contact Tronair immediately. Do not attempt to repair or disassemble a product without first contacting Tronair, any action may affect warranty coverage. When you contact Tronair be prepared to provide the following information:

- a) Product Model Number
- b) Product Serial Number
- c) Description of the problem

If warranty coverage is approved, either replacement parts will be sent or the product will have to be returned to Tronair for repairs. If the product is to be returned, a Return Material Authorization (RMA) number will be issued for reference purposes on any shipping documents. Failure to obtain a RMA in advance of returning an item will result in a service fee. A decision on the extent of warranty coverage on returned products is reserved pending inspection at Tronair. Any shipments to Tronair must be shipped freight prepaid. Freight costs on shipments to customers will be paid by Tronair on any warranty claims only. Any unauthorized modification of the Tronair products or use of the Tronair products in violation of cautions and warnings in any manual (including updates) or safety bulletins published or delivered by Tronair will immediately void any warranty, express or implied.

The obligations of Tronair expressly stated herein are in lieu of all other warranties or conditions expressed or implied. **Any unauthorized modification of the Tronair products or use of the Tronair products in violations of cautions and warnings in any manual (including updates) or safety bulletins published or delivered by Tronair will immediately void any warranty, express or implied and Tronair disclaims any and all liability for injury (WITHOUT LIMITATION and including DEATH), loss or damage arising from or relating to such misuse.**

Parts List

When ordering replacement parts/kits, please specify model, serial number and color of your unit.

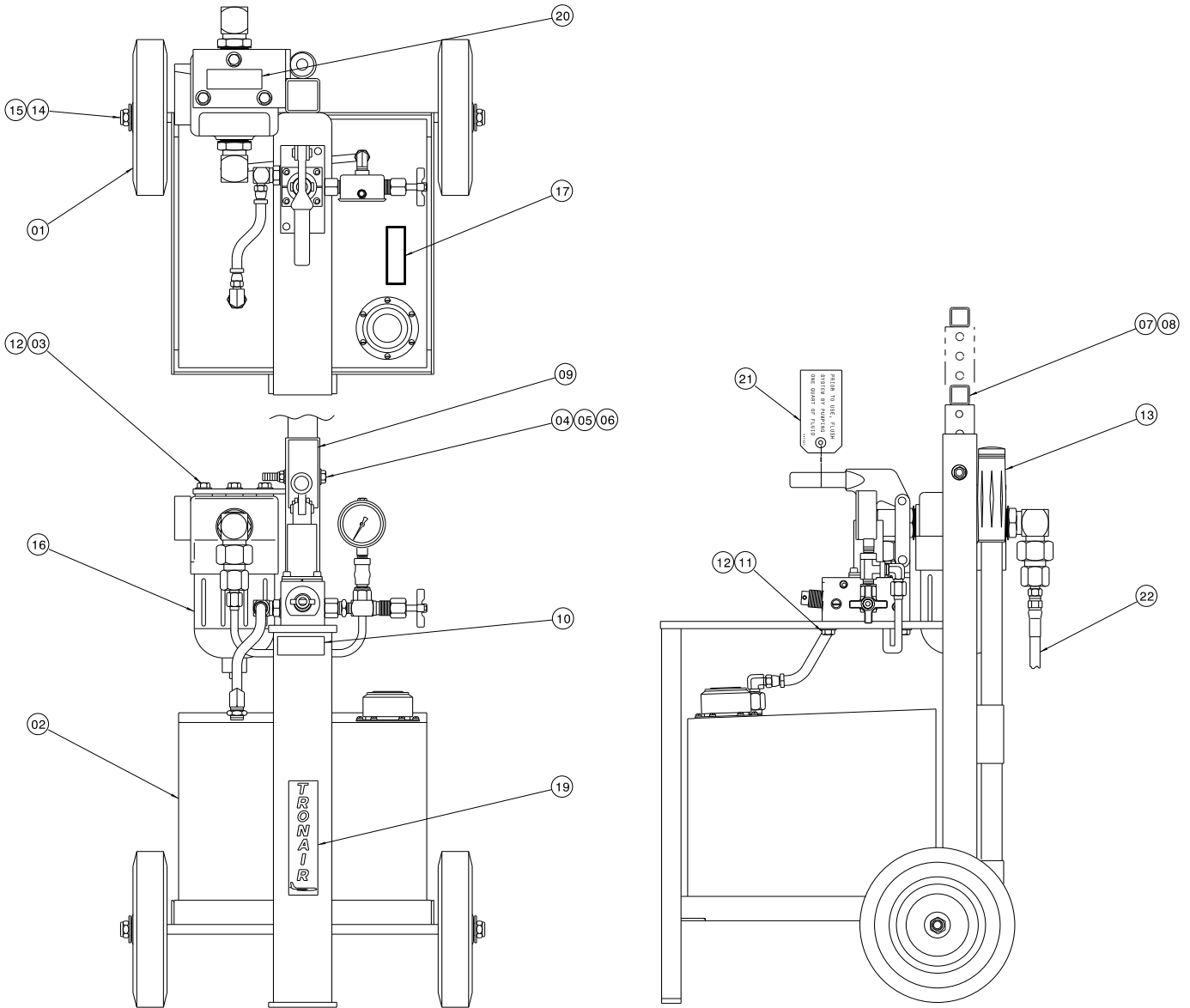

Item	Part Number	Description	Qty
1	U-1001-01	Wheel, 8" Diameter	1
2	Z-4182-01	Weldment, HSU Frame	1
3	G-1100-107006	Bolt, Hex Head GR 5, 5/8 - 16 x 3/4 Long	Ref
4	G-1202-1075	ESN, 3/8 - 24	1
5	G-1250-1070N	Flatwasher, 3/8 Narrow	2
6	G-1100-107524	Bolt, Hex Head GR 5, 5/8 - 24 x 2 1/2 Long	1
7	Z-1083-01	Weldment, handle	1
8	H-11443	Cap, End	2
9	V-1779	Label, Serial Number (CE)	1
10	V-1001	Label, Made In USA	1
11	G-1100-107010	Bolt, Hex Head GR 5, 5/8 - 16 x 1 Long	Ref
12	G-1251-1070R	Lockwasher, 3/8 Regular	Ref
13	H-1009-01	Handle, Pump	1

Parts List

When ordering replacement parts/kits, please specify model, serial number and color of your unit.

Item	Part Number	Description	Qty
14	G-1250-1090N	Flatwasher, ½ Narrow	4
15	G-1203-1095	ESN, ½ - 20	2
19	V-1198	Label, Tronair	1
21	V-1431	Tag, Flush System	1

THE FOLLOWING PARTS ARE FLUID SPECIFIC

Parts List - 06-4035C0500

MIL-PRF-5606/MIL-PRF-83282

Item	Part Number	Description	Qty
16	Z-7737-01	Assembly, Hydraulic	1
17	V-1380	Label, Fluid	1
20	V-1526	Label, Filter Element	1
22	TF-1043-01*180	Assembly, Hose ¼ x 180 Long	1

Parts List - 06-4035C0800

MIL-L-23699, MIL-PRF-87257

Item	Part Number	Description	Qty
16	Z-7737-03	Assembly, Hydraulic	1
17	V-1035	Label, Fluid	1
20	V-1526	Label, Filter Element	1
22	TF-1038-14*180	Assembly, Hose ¼ x 180 Long	1

Parts List - 06-4035C3300

HyJet V

Item	Part Number	Description	Qty
16	Z-7737-02	Assembly, Hydraulic	1
17	V-2582	Label, Fluid	1
20	V-1460	Label, Filter Element	1
22	TF-1041-05*180	Assembly, Hose ¼ x 180 Long	1

Parts List - 06-4035C3600

Phosphate Ester

Item	Part Number	Description	Qty
16	Z-7737-02	Assembly, Hydraulic	1
17	V-1100	Label, Fluid	1
20	V-1460	Label, Filter Element	1
22	TF-1041-05*180	Assembly, Hose ¼ x 180 Long	1

HC-1101 Valve Shut-Off

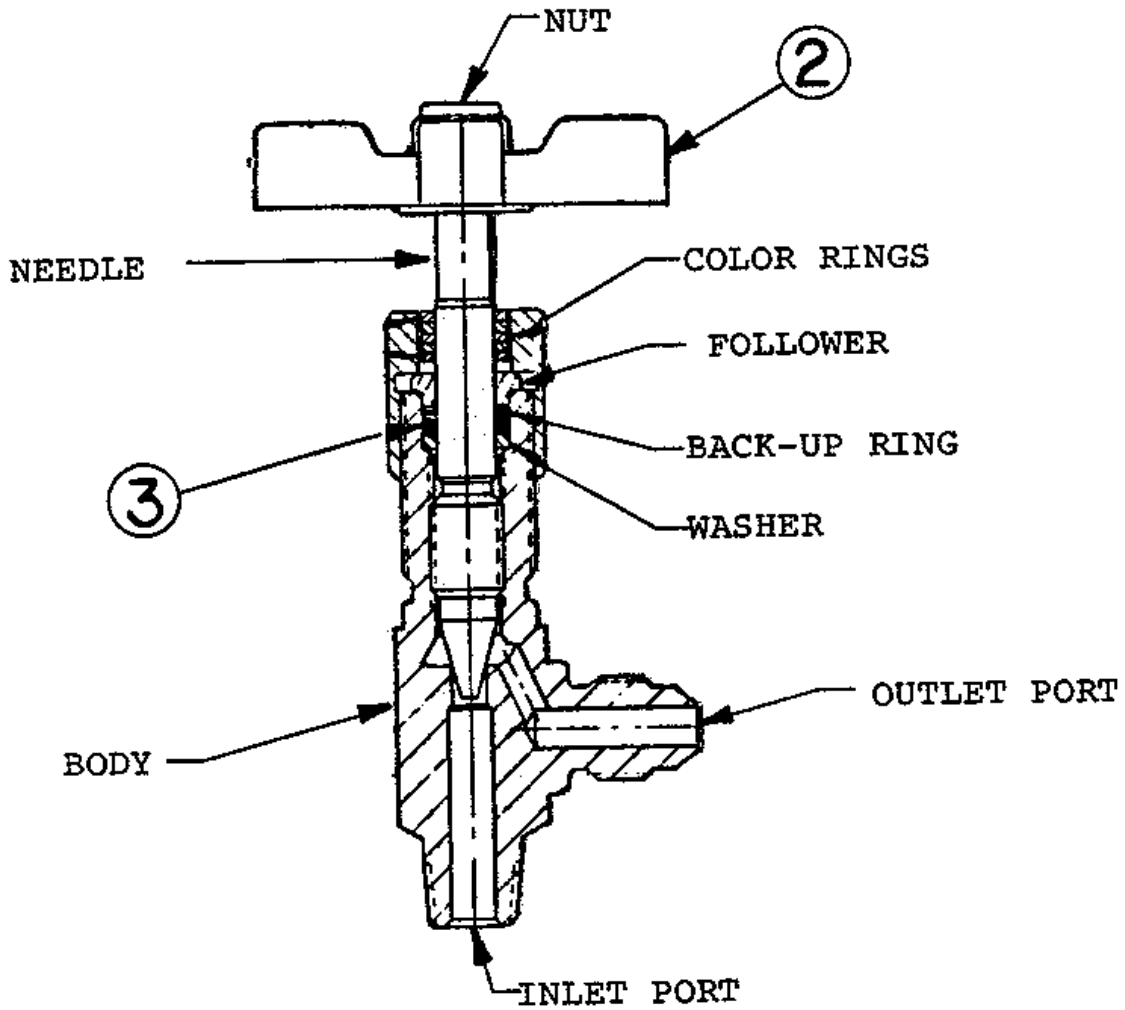

Parts List - 06-4035C0500, 06-4035C0800
 MIL-PRF-5606/MIL-PRF-83282, MIL-L-23699/MIL-PRF-87257

Item	Part Number	Description	Qty
	HC-1101-01	Assembly, Valve (Complete Component)	1
2	HC-1082	Handle, Valve	1
3	HC-2000-011	O-ring	1

Parts List - 06-4035C3300, 06-4035C3600
 HyJet V, Phosphate Ester

Item	Part Number	Description	Qty
	HC-1101-02	Assembly, Valve (Complete Component)	1
2	HC-1082	Handle, Valve	1
3	HC-2006-011	O-ring	1

HC-1675 Pressure Filter Assembly

06-4035C0500, 06-4035C0800
 MIL-PRF-5606/MIL-PRF-83282, MIL-L-23699/MIL-PRF-87257

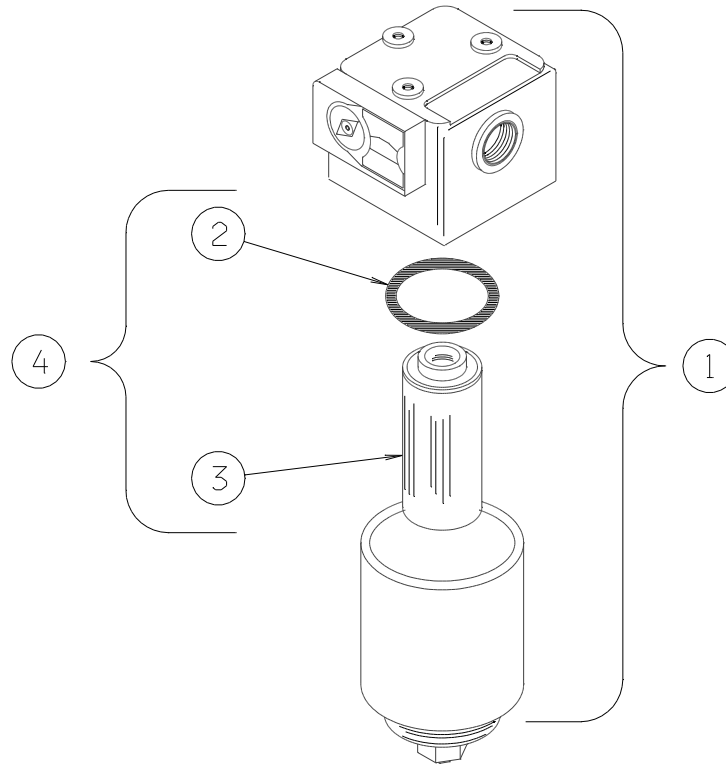

Item	Part Number	Description	Qty
1	HC-1675	Assembly, Pressure Filter	1
4	K-2318	Kit, Filter Element Replacement; consists of:	
2	HC-2000-235	O-ring, Series 2	1
3	HC-1676	Element, Filter	1

HC-1675 Pressure Filter Assembly

06-4035C3300, 06-4035C3600
 HyJet V, Phosphate Ester

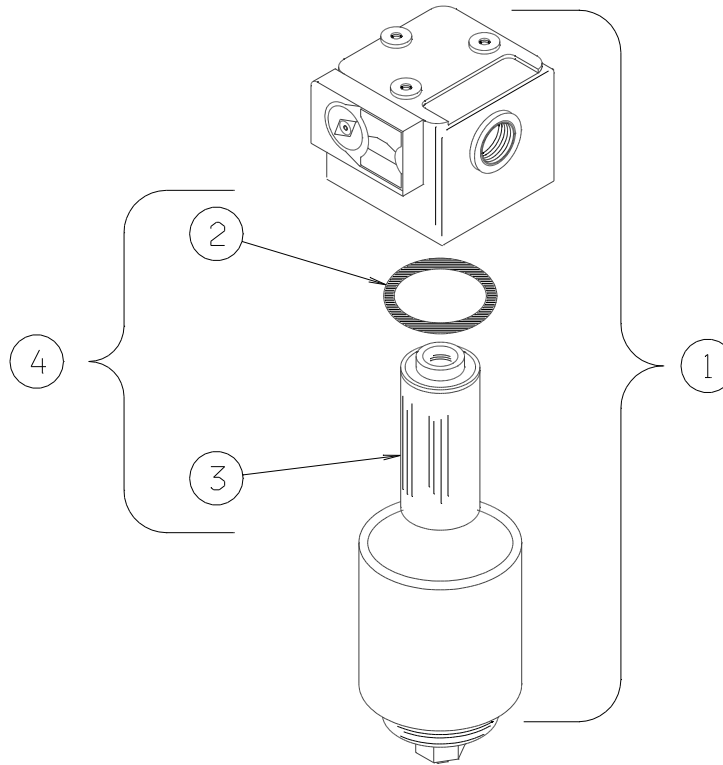

Item	Part Number	Description	Qty
1	HC-1581	Assembly, Pressure Filter	1
4	K-2131	Kit, Filter Element Replacement; consists of:	
2	HC-2006-235	O-ring, Series 2	1
3	HC-1587	Element, Filter	1



APPENDIX I

**HC-2542
Mineral Base
Hand Pump
Parts List**



HC-2542 Hydraulic Hand Pump

Parts List With Illustrations

02/2011 – Rev. 01

**** When ordering Replacement Parts/Kits, please specify Model, Color and Serial Number of your Unit.****

This product can not be modified without the written approval of Tronair, Inc. Any modifications done without written approval voids all warranties and releases Tronair, Inc., its suppliers, distributors, employees, or financial institutions from any liability from consequences that may occur. Only Tronair OEM replacement parts shall be used.

Parts List

This pump is compatible with MIL-PRF-5606/MIL-PRF-83282 Hydraulic Fluids.

Reference Parts List Illustration on following page

Item	Part Number	Description	Qty
1	583-120	Plug	1
2	09-ADDF-04-20 x 56	Tie Rod	4
3	582-120	Flange, Retaining	3
4	563-121	Tube	4
5	562-125	Piston - High Pressure	5
8	564-120	Retainer Plate	1
9	560-120	Valve Body	1
12	577-120	Spring, Outlet - Low Pressure	1
15	CXD-000003-001	Body	1
16	CXD-110028-003	Relief Assembly, 5000	1
18	505-001	Plug, Valve Body	3
21	514-034	Spring, Outlet Check	1
22	517-000	Ball, Outlet Check	4
24	570-120	Spring - Bypass	1
25	571-121	Piston - Bypass	1
26	569-120	Ball - Bypass	1
28	566-125	Piston - Low Pressure	1
33	516-120	Spring - High Pressure Inlet	1
34	573-120	Spring - Intake Low Pressure	1
35	CXD-000003-002	Screw, Release	1
36	519-0000	Roll Pin	1
37	CXD-000003-004	Release Screw Retainer	1
39	09-AYDF-06-16X03	Lock Screw	1
40	516-120	Spring, Ball Check	1
	SRK-PL-000	Assembly ; consists of:	
27	508-000	Pivot	1
29	512-000	Strap	2
30	510-001	Pin Linkage Assembly	2
31	531-000	Clevis Pin Assembly	1
32	509-C00	Handle Bracket	1
	SRK-110028	Kit ; consists of:	
6	574-125	High Pressure Piston Seal	5
7	526-120	O-Ring, Buna	1
10	01-127-A070	O-Ring, Buna	1
11	565-120	O-Ring, Buna	1
13	523-000	O-Ring, Buna	4
14	02-008-TL62	Back-Up Teflon	4
17	01-114-A070	O-Ring, Buna	1
19	02-012-TL62	Back-Up Split	1
20	01-012-A070	O-Ring, Buna	1
23	522-000	O-Ring, Buna	1
38	521-000	O-Ring, Buna	1

Parts List Illustration

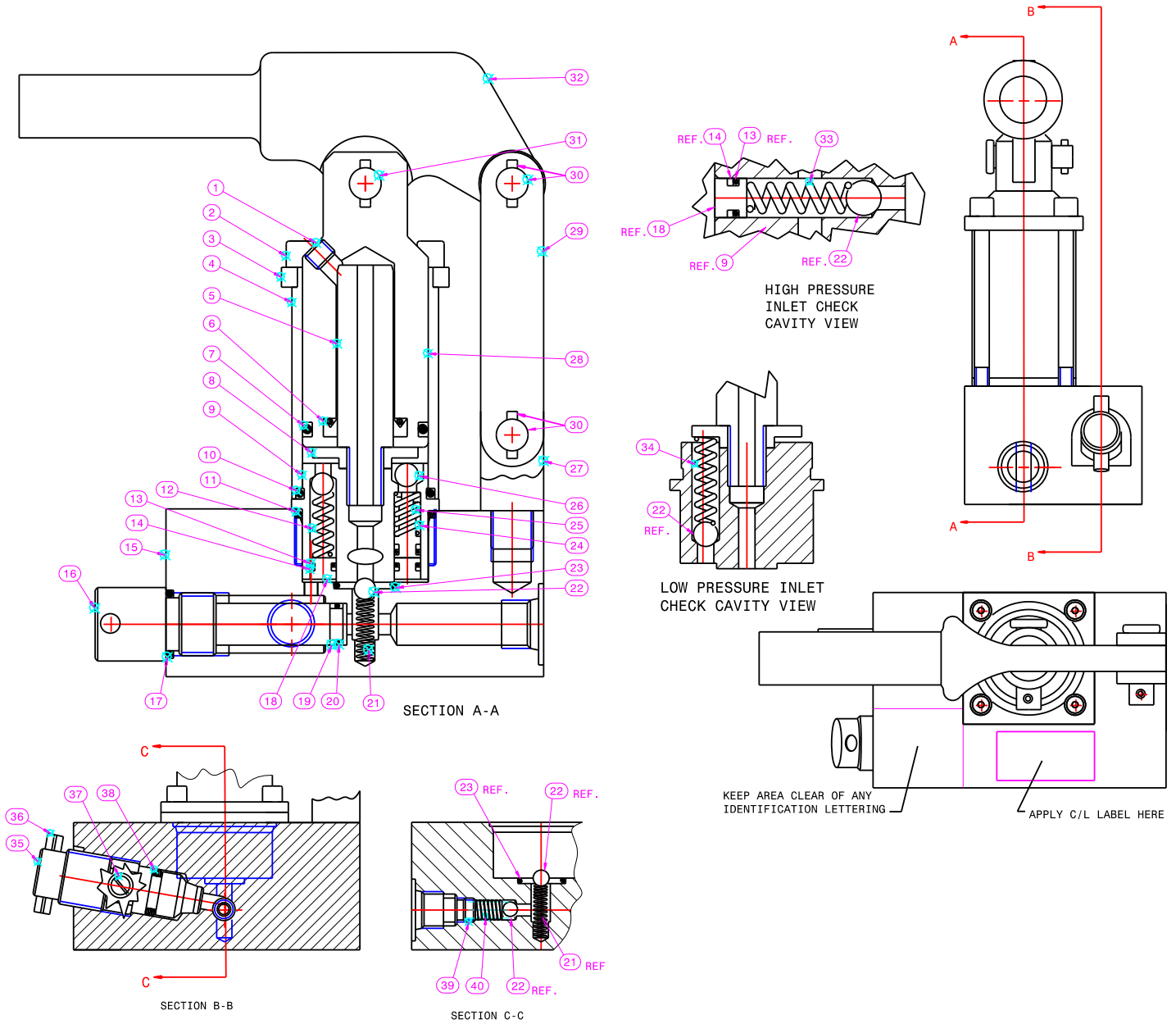



APPENDIX II

**HC-2557
Phosphate Ester
Hand Pump
Parts List**



HC-2557 Hydraulic Hand Pump

Parts List With Illustrations

01/2012 – Rev. 01

When ordering Replacement Parts/Kits, please specify Model, Color and Serial Number of your Unit.

This product can not be modified without the written approval of Tronair, Inc. Any modifications done without written approval voids all warranties and releases Tronair, Inc., its suppliers, distributors, employees, or financial institutions from any liability from consequences that may occur. Only Tronair OEM replacement parts shall be used.

Parts List

This pump is compatible with Phosphate Ester Hydraulic Fluids.

Reference Parts List Illustration on following page.

Item	Part Number	Description	Qty
1	583-120	Plug	1
2	09-ADDF-04-20 x 56	Tie Rod	4
3	582-120	Flange, Retaining	3
4	563-121	Tube	4
5	562-125	Piston - High Pressure	5
8	564-120	Retainer Plate	1
9	560-120	Valve Body	1
12	577-120	Spring, Outlet - Low Pressure	1
15	CXD-000003-001	Body	1
16	CXD-110028-003	Relief Assembly, 5000	1
18	505-001	Plug, Valve Body	3
21	514-034	Spring, Outlet Check	1
22	517-000	Ball, Outlet Check	4
24	570-120	Spring - Bypass	1
25	571-121	Piston - Bypass	1
26	569-120	Ball - Bypass	1
28	566-125	Piston - Low Pressure	1
33	516-120	Spring - High Pressure Inlet	1
34	573-120	Spring - Intake Low Pressure	1
35	CXD-000003-002	Screw, Release	1
36	519-0000	Roll Pin	1
37	CXD-000003-004	Release Screw Retainer	1
39	09-AYDF-06-16X03	Lock Screw	1
40	516-120	Spring, Ball Check	1
	SRK-PL-000	Assembly , consists of:	
27	508-000	Pivot	1
29	512-000	Strap	2
30	510-001	Pin Linkage Assembly	2
31	531-000	Clevis Pin Assembly	1
32	509-C00	Handle Bracket	1
		Kit , consists of:	
6		High Pressure Piston Seal	5
7		O-Ring, EPR	1
10		O-Ring, EPR	1
11		O-Ring, EPR	1
13		O-Ring, EPR	4
14		Back-Up Teflon	4
17		O-Ring, EPR	1
19		Back-Up Split	1
20		O-Ring, EPR	1
23		O-Ring, EPR	1
38		O-Ring, EPR	1

Parts List Illustration

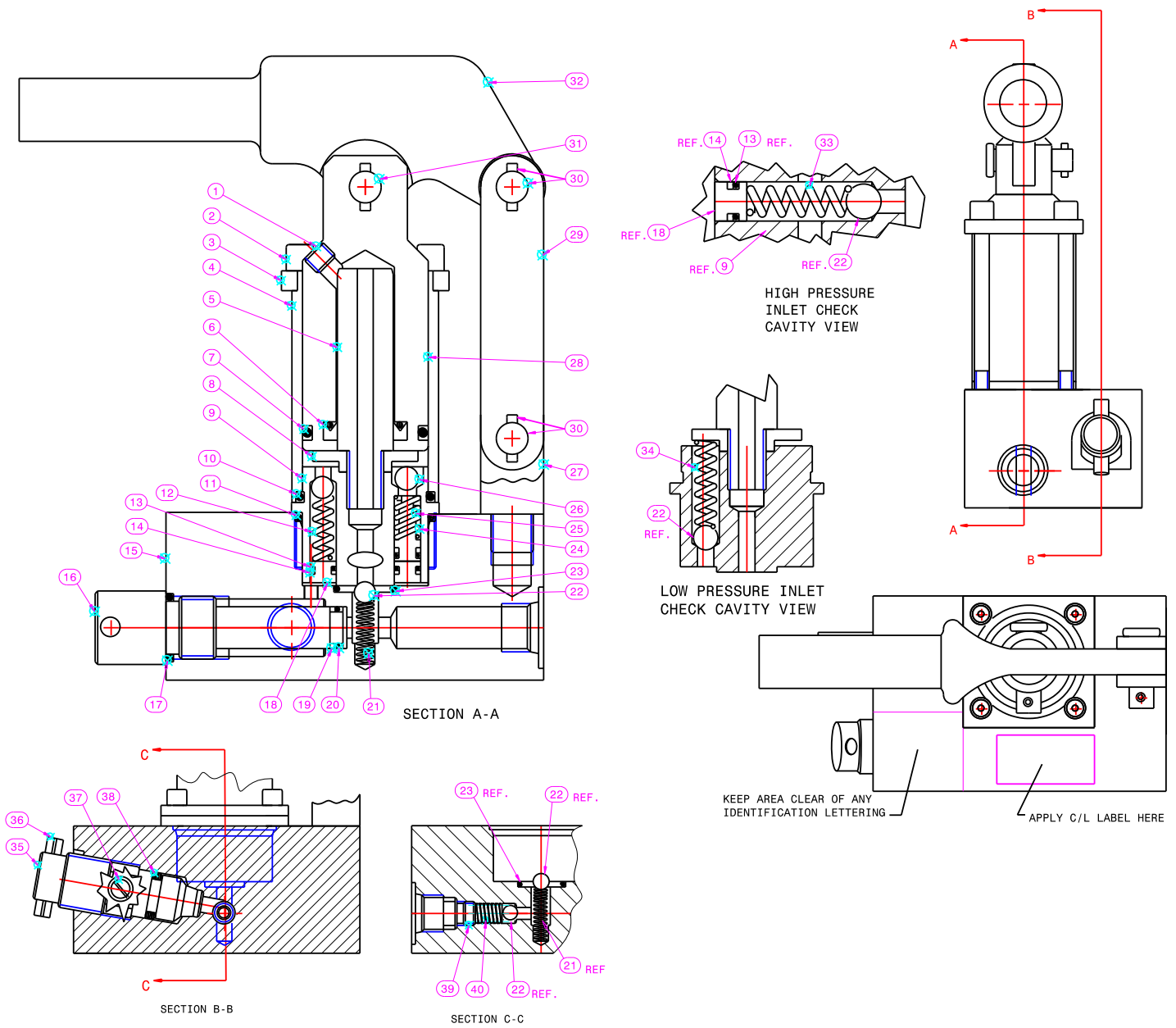



APPENDIX I

**Declaration
Of
Conformity**



DECLARATION of CONFORMITY

The design, development and manufacture is in accordance with European Community guidelines

06-4035C0500
06-4035C0800
06-4035C3300
06-4035C3600

Relevant provisions complied with by the machinery:
2006/42/EC

Identification of person empowered to sign on behalf of the manufacturer:

A handwritten signature in black ink that reads "David L. Kidd". The signature is written in a cursive style and is positioned above a solid horizontal line.

Quality Assurance Representative