

Model: 01-0571-0011
Bombardier CRJ-100/200
Bombardier Challenger 850
Hawker 4000
Multi-Head



07/2007 – Rev. 06

Includes Illustrated Parts Lists

REVISION	DATE	TEXT AFFECTED
03	12/2003	2.1 Safety Information/General - warning added
04	09/2004	1.1 Specifications - added Hawker Horizon to Aircraft Application Modified 3.1 Maintenance Checklist
05	01/2007	Added CE marking
06	07/2007	Modified 3.0 Operation

TABLE OF CONTENTS

	<u>PAGE</u>
1.0 DESCRIPTION	1
1.1 SPECIFICATIONS	1
1.2 FEATURES	1
2.0 SAFETY INFORMATION.....	2
2.1 GENERAL.....	2
3.0 OPERATION.....	2
3.1 MAINTENANCE CHECKLIST	2
3.2 Usage Procedure	2
4.0 TRAINING.....	3
4.1 Training Requirements	3
4.2 Training Program.....	3
4.3 Operator Training	3
5.0 PROVISION OF SPARES	3
5.1 Parts List.....	3

Tronair towbars/heads must only be used with matching Tronair heads/towbars, and Tronair shear pins.

This product can not be modified without the written approval of Tronair, Inc. Any modifications done without written approval voids all warranties and releases Tronair, Inc., its suppliers, distributors, employees, or financial institutions from any liability from consequences that may occur. Only Tronair OEM replacement parts shall be used.

1.0 DESCRIPTION

The Tronair Model 01-0571-0011 Multi-Head is a towbar head attachment for the Bombardier CRJ 100 and CRJ 200 and the Hawker Horizon aircraft.

The towbar head attachment is designed for use with Tronair Multi-Head Towbar Models 01-1201-0010, 01-1202-0000, 01-1215-0000, 01-1216-0000 and 01-1290-0100 for towing the previously stated aircraft. The towbar head attachments use sliding pins to interface with the aircraft tow point.

1.1 SPECIFICATIONS

- Aircraft Application(s): Bombardier CRJ 100 and CRJ 200 Aircraft
Hawker Horizon
- Dimensions: Width 29 ⁵/₁₆ in (74.5 cm)
Length 30 ³/₈ in (77.2 cm) overall
Height 4 in (10.2 cm)
- Weight: 45 lbs (20.4 kg)
- Finish: Blue Powder Coat
- Aircraft Gross Weight (Maximum): 53,000 lbs (20.04 metric tons)

1.2 FEATURES

Reference Figure 1

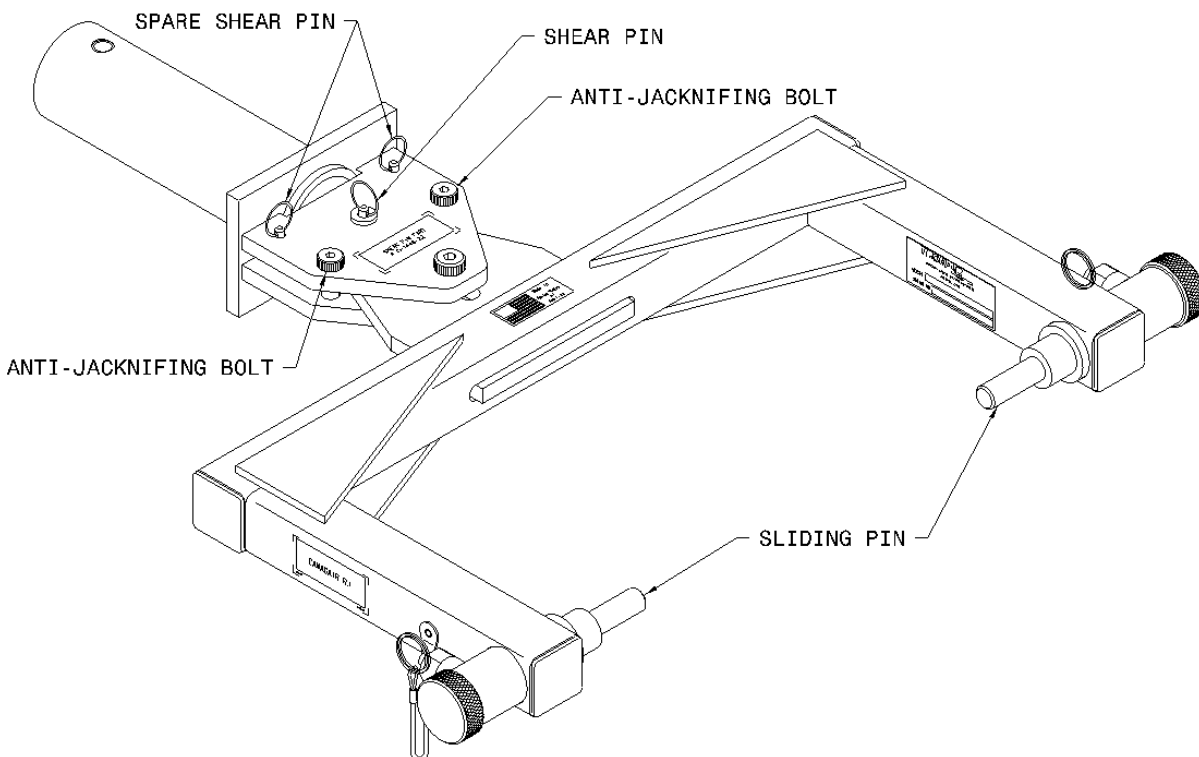

FIGURE 1

2.0 SAFETY INFORMATION

2.1 GENERAL

The Tronair Model 01-0571-0011 towbar head attachment is used for towing Bombardier CRJ 100 and CRJ 200 AND Hawker Horizon aircraft only.

To ensure safe operation, please read the following statements and understand their meaning. This manual contains safety precautions which are explained as follows. Please read carefully.



WARNING! Warning is used to indicate the presence of a hazard that can cause **severe personal injury, death, and/or substantial property damage** if the Warning notice is ignored.

CAUTION! Caution is used to indicate the presence of a hazard which will or can cause **minor personal injury or property damage** if the Caution notice is ignored.

3.0 OPERATION



WARNING!

A damaged or bent towbar should not be used. Towbar should be repaired or replaced.

WARNING!



Tronair recommends the use of a towbar with a category 1 or category 2 tug and aircraft not exceeding 75,000 lbs gross weight. Using the towbar with aircraft weighing in excess of this specific limitation may result in excessive loads and stresses being applied to the towbar and/or the aircraft. These excessive loads may cause failure of the towbar which could cause damage (INCLUDING WITHOUT LIMITATION to the aircraft) and/or personal injury OR DEATH. TRONAIR MAKES NO REPRESENTATION, WARRANTY OR GUARANTEE AS TO SUCH MISUSE AND DISCLAIMS ANY AND ALL LIABILITY FOR INJURY, LOSS OR DAMAGE ARISING FROM OR RELATING TO SUCH MISUSE.

3.1 MAINTENANCE CHECKLIST

- Inspect all welds for cracks. If any weld cracks are found, remove towbar head from service and contact Tronair for repair.
- Inspect shear pin. Ensure that the shear pin is not bent, broken, or missing. Replace the shear pin if required. Only use the Tronair specified shear pin.



WARNING!

Damage to the aircraft can occur if it is towed without shear protection.

- Inspect the sliding pins for bending, cracks, and wear. Do not use a sliding pin that is bent, cracked or excessively worn. Contact Tronair for replacement.
- Verify that sliding pins can move freely within their housing. If any binding occurs, inspect the sliding pin for bending and the housing for roundness. If either of these situations are present, contact Tronair for repair options.
- Check the sliding pin retaining pin assemblies. Ensure that they positively lock the sliding pins into position. If they do not, contact Tronair for repairs.
- Check the shoulder bolt connections through the shear plates. Verify that they are NOT clamping the shear plates together. There should not be any clamping force applied to the shear plates so the assembly functions properly.
- Inspect the shear plates for bending. If any bending has occurred, remove towbar head from service and contact Tronair for repair.
- Inspect the head and side rails for bending. If bending has occurred, contact Tronair for repair.
- Inspect the head plate for bending. If bending has occurred, contact Tronair for repairs.
- Inspect the shear pin bushings for cracking or chipping. If the bushings have cracks or chips, contact Tronair for replacement. Only use Tronair specified shear pin bushings

3.2 Usage Procedure

Secure the towbar head attachment using the ball lok-T pin (supplied with the multi-head towbar) onto one of the following Tronair Multi-Head Towbar Models:

- 01-1201-0010
- 01-1202-0000
- 01-1290-0100
- 01-1215-0000
- 01-1216-0000

4.0 TRAINING

4.1 Training Requirements

The employer of the operator is responsible for providing a training program sufficient for the safe operation of the towbar.

4.2 Training Program

The employer-provided operator training program should cover safety procedures concerning use of the towbar in and around the aircraft at the servicing location.

4.3 Operator Training

The operator training should provide the required training for safe operation of towbar.

NOTE: Maintenance and Trouble Shooting are to be performed by the skilled and trained technician.

5.0 PROVISION OF SPARES

Spare parts may be obtained from the manufacturer:

TRONAIR, Inc.

1 Air Cargo Pkwy East

Swanton, Ohio 43558 USA

Telephone: (419) 866-6301 or 800-426-6301

Fax: (419) 867-0634

E-mail: sales@tronair.com

Website: www.tronair.com

5.1 Parts List

Reference Parts List and Illustration on following page.

6.0 GUARANTEES/LIMITATION OF LIABILITY

Tronair products are warranted to be free of manufacturing or material defects for a period of one year after shipment to the original customer. This is solely limited to the repair or replacement of defective components. This warranty does not cover the following items:

- a) Parts required for normal maintenance
- b) Parts covered by a component manufacturers warranty
- c) Replacement parts have a 90-day warranty from date of shipment

If you have a problem that may require service, contact Tronair immediately. Do not attempt to repair or disassemble a product without first contacting Tronair, any action may affect warranty coverage. When you contact Tronair be prepared to provide the following information:

- a) Product Model Number
- b) Product Serial Number
- c) Description of the problem

If warranty coverage is approved, either replacement parts will be sent or the product will have to be returned to Tronair for repairs. If the product is to be returned, a Return Material Authorization (RMA) number will be issued for reference purposes on any shipping documents. Failure to obtain a RMA in advance of returning an item will result in a service fee. A decision on the extent of warranty coverage on returned products is reserved pending inspection at Tronair. Any shipments to Tronair must be shipped freight prepaid. Freight costs on shipments to customers will be paid by Tronair on any warranty claims only. Any unauthorized modification of the Tronair products or use of the Tronair products in violation of cautions and warnings in any manual (including updates) or safety bulletins published or delivered by Tronair will immediately void any warranty, express or implied.

The obligations of Tronair expressly stated herein are in lieu of all other warranties or conditions expressed or implied. **Any unauthorized modification of the Tronair products or use of the Tronair products in violations of cautions and warnings in any manual (including updates) or safety bulletins published or delivered by Tronair will immediately void any warranty, express or implied and Tronair disclaims any and all liability for injury (WITHOUT LIMITATION and including DEATH), loss or damage arising from or relating to such misuse.**

Parts List

When ordering replacement parts/kits, please specify model, serial number and color of your unit.

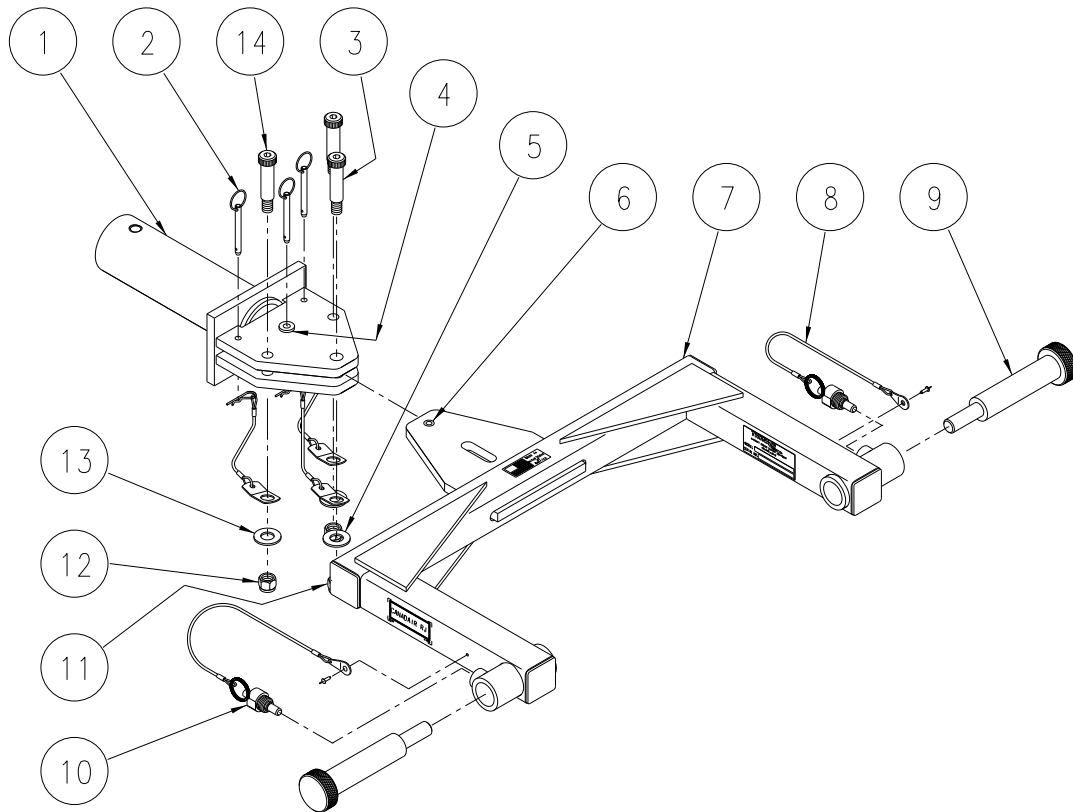

Item	Part Number	Description	Qty
1	Z-2628-01	Assembly, Shear Plate - <i>Not Sold Separately</i>	Ref
2	G-1446-22	Pin, Shear	3
3	G-1155-109216	Screw, Hex Socket Head Shoulder (½-13 x 1¾" long)	1
4	H-1724-06	Bushing	2
5	G-1250-1110N	Flatwasher, ⅝ Narrow	1
6	H-1725-11	Bushing	1
7	Z-5094-01	Weldment, Head - <i>Not Sold Separately</i>	Ref
8	H-1026*07.0	Assembly, Lanyard	2
9	R-1430	Pin, Sliding	2
10	Z-2626	Assembly, Handle (includes Mounting Hardware)	2
11	G-1202-1090	Stopnut, ½-13 Elastic	1
12	G-1202-1070	Stopnut, ⅜ -16 Elastic	2
13	G-1250-1090N	Flatwasher, ½ Narrow	2
14	G-1155-107216	Screw, Hex Socket Head Shoulder (⅜ -16 x 1¾" long)	2



APPENDIX I

Declaration of Conformity



DECLARATION of CONFORMITY

The design, development and manufacture is in accordance with European Community guidelines

Multi-Head Towbar
01-0571-0011

Relevant provisions complied with by the machinery:
2006/42/EC

Relevant standards complied with by the machinery:
EN ISO 12100-1

Identification of person empowered to sign on behalf of the Manufacturer:

A handwritten signature in cursive script that reads "Patrick Finch". The signature is written in black ink and is positioned above a horizontal line.

Quality Assurance Representative

Standard Attachment Heads

Models:

01-0506-0000, 01-0507-0000, 01-0508-0000,
01-0511-0000, 01-0513-0000, 01-0514-0000,
01-0516-0000, 01-0518-0000, 01-0518-0010,
01-0524-0000, 01-0525-0000, 01-0529-0000,
01-0531-0000, 01-0532-0000, 01-0534-0000,
01-0538-0000, 01-0540-0000, 01-0540-0010,
01-0542-0000, 01-0542-0010, 01-0543-0000,
01-0545-0000, 01-0545-0010, 01-0545-0011,
01-0546-0000, 01-0547-0000, 01-0551-0000,
01-0551-0010, 01-0552-0000, 01-0552-0010,
01-0552-0011, 01-0556-0000, 01-0569-0000,
01-0570-0000, 01-0570-0010, 01-0571-0000,
01-0571-0010, 01-0571-0011, 01-0577-0000,
01-0577-0010, 01-0579-0000, 01-0581-0000,
01-0582-0000, 01-0582-0010, 01-0582-0000,
01-0582-0011, 01-0597-0000, 01-0598-0000,
01-0599-0000, 01-0801-0000, 01-0801-0010,
01-0802-0000, 01-0802-0010, 01-0803-0000,
01-0600-0000

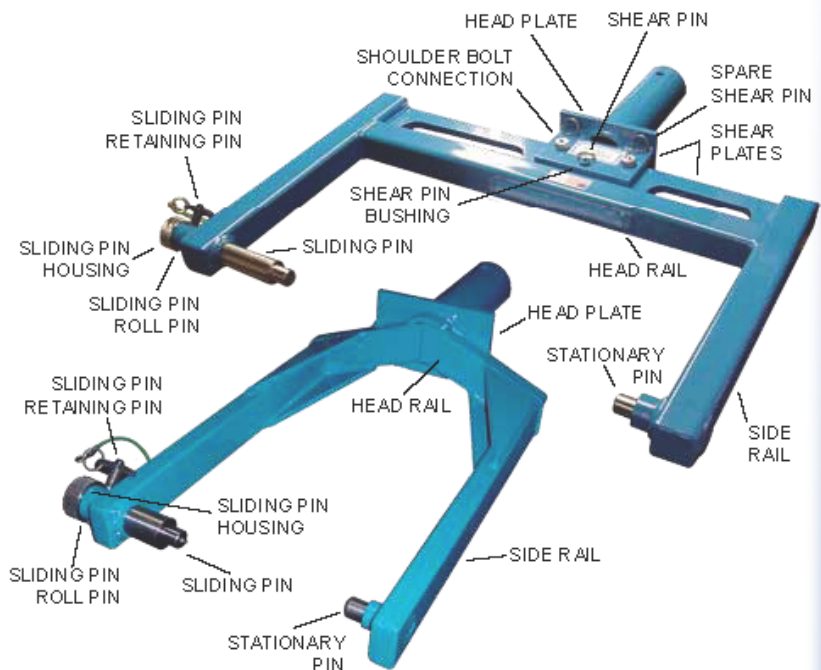

Tronair recommends towbar inspections at least once a week.

- Inspect for weld cracks. If found remove the towbar multi-head from service and contact Tronair for repair.
- Inspect the side rails, head rail, and head plate for bending. If found remove the towbar multi-head from service and contact Tronair for repair.
- For towbar multi-heads with shear, inspect the shear plates for bending. If found remove the towbar multi-head from service and contact Tronair for repair.
- Inspect the sliding pin(s) and (if applicable) the stationary pin for bending, cracks, and excessive wear. If found remove the towbar multi-head from service and contact Tronair or your Tronair distributor for replacement.
- Ensure the sliding pin(s) can move freely within its housing. If any binding occurs, inspect the sliding pin for bending and the housing for out-of-roundness. If either condition exists, contact Tronair for repair options.
- Inspect the sliding pin retaining pin assembly. Ensure the retaining pin is not missing. Ensure the retaining pin can engage the sliding pin through its housing and that it positively locks the sliding pin into place. If it does not, contact Tronair or your Tronair distributor for replacement/repair.
- Verify the sliding pin is secure to the towbar multi-head via its lanyard. Replace the lanyard if missing.
- Inspect the sliding pin roll pin (located through the sliding pin housing). Ensure the sliding pin roll pin is not loose or missing, contact Tronair or your Tronair distributor for replacement if needed.
- For towbar multi-heads with shear, check the shoulder bolt connections through the shear plates. Verify they are not clamping the shear plates together. There should not be any clamping force applied to the shear plates so the assembly functions properly. If required, back the stopnut off to remove any clamping force applied.
- For towbar multi-heads with shear, inspect the shear pin. If the shear pin is bent, broken, or missing contact Tronair or your Tronair distributor for replacement. Tronair recommends purchasing spare shear pins for rapid replacement, use only Tronair specified shear pins.
- For towbar multi-heads with shear, inspect the shear pin bushings. If the shear pin bushings are cracked or chipped, contact Tronair or your Tronair distributor for replacement, use only Tronair specified shear pin bushings.
- Inspect all steel components for signs of rust. Touch up with paint as required.

INS-1789

www.tronair.com

Tronair • Email: sales@tronair.com • Phone: 419-866-6301 or 800-426-6301 • Fax: 419-867-0634

Asia Sales Offices: China - Email: tronairchina@tronair.com • Phone: 86-592-5560735 • Fax: 86-592-5563132

Asia/Australia - Email: tronairasia@tronair.com • Phone: 66-2665-6511 • Fax: 66-2204-1858

Europe, Middle East & Africa Sales Office • Email: saleseurope@tronair.com • Phone: 44-0-113-245-3300 • Fax: 44-0-113-322-0436